

OCULUS | Easyfield® C

Perimeter

NEW



 OCULUS®

www.oculus.de

OCULUS Easyfield® C

The right choice for all your needs

The OCULUS Easyfield® C is an exciting compact perimeter to do static perimetry up to 30°. It has been designed for the combined use as visual field screener and perimeter, offering features usually available only in large units. The closed bowl with a 11.81" (30cm) radius and distance adapted lens conforms to the Goldmann standard and fulfills the ISO-12866 norm for perimeters.

The Easyfield® C has an LED grid with 135 fixed test locations and can test the common 10-2, 24-2 and 30-2 patterns. The novel SPARK test strategy leads to faster and more stable threshold tests providing improved diagnostic abilities. Besides the standard field indices the Easyfield® C delivers the evaluations of the innovative Glaucoma Staging Program (GSP) and the classifications provided by the Glaucoma Staging System 2 (GSS2) of Dr. Paolo Brusini.

Advantages

- Fast
- Compact
- Lightweight
- Robust
- Performs standard automated perimetry (SAP)
- Advanced statistics and analysis software

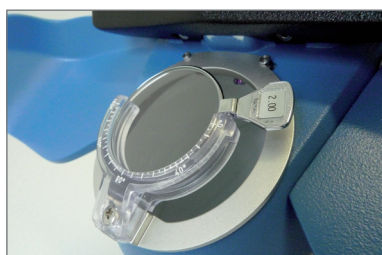

> Lens holder



> Double chinrest

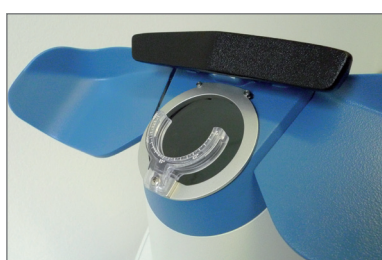

> Eye shields



Hardware Facelift

- Redesigned headrest with lateral eye shields allows measurements without an eye-patch, saving precious time in the preparation for the test.
- The completely new, vertically adjustable double chinrest further improves the quality of examinations by sensibly increasing the comfort of the patients.
- The stylish design of the chinrest is adapted to the ergonomically movable perimeter cone for complete versatility.
- The high resolution camera with clear video control images of the patient's eye supports the reliability of exams.
- Standard USB interface offers the up-to-date connectivity of the OCULUS Easyfield® C with any external PC. The network integration is straightforward.

The new features

The new OCULUS Easyfield® C was specifically designed to support glaucoma care, through preventive screening or complete visual field tests and progression analysis. However, the versatility of the device allows for all common tests of the central visual field, independent of the clinical picture.

Enhanced test methods

- **SPARK Precision** strategy for faster and more reliable threshold perimetry. Complete visual field test of glaucoma patients is performed in only 3 minutes per eye, the measurement excels in the stability of the results for improved progression analysis.
- **SPARK Light** strategy for follow-up or screening examinations. For patients with perimetric history the quality of the results is similar to the ones of the SPARK Precision, with a further halving of the test duration.
- **SPARK Training** strategy for patient training and reduction of learning effects in the standard perimetry. The 40 s long exam can be successfully used also as a screening test.
- **CLIP** strategy for rapid threshold tests with an increased comfort sensation for the patients.

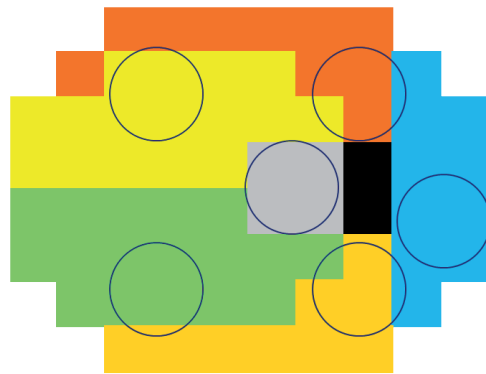

> SPARK takes advantage of correlations between areas in the visual field in order to speed up threshold examinations

Advanced analysis tools

- **Threshold Noiseless Trend (TNT)** for precise evaluation of progression in visual field data. TNT combined with the ultrafast SPARK strategy improves significantly the sensitivity of progression detection in early glaucoma.
- **Glaucoma Staging Program (GSP)** for thorough assessment of individual visual field findings using modern algorithms of pattern recognition. Besides the unique contribution to early glaucoma diagnosis GSP can additionally substantiate the clinical evaluation of test results.

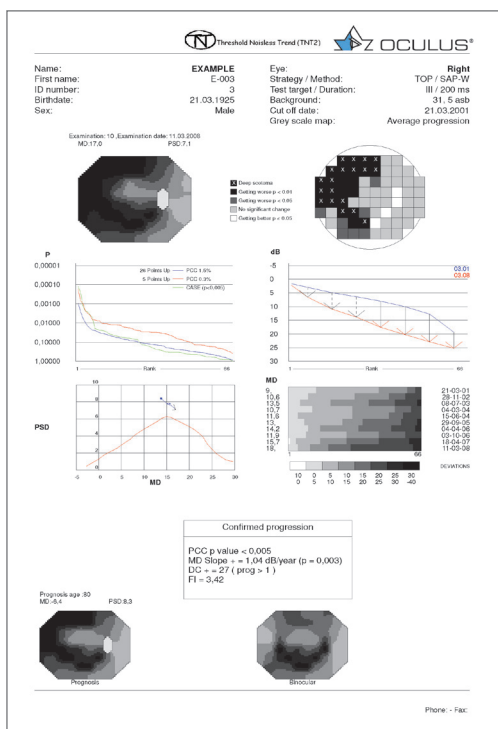

> TNT printout

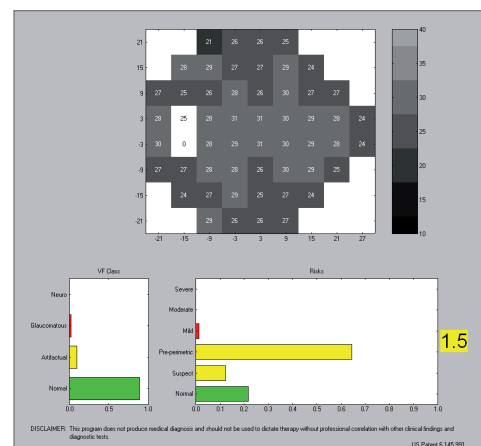

> GSP results display

Technical data

OCULUS Easyfield® C

Static perimetry	
Programs	Pre-defined glaucoma, macula, screening and neurological tests User-defined tests
Strategies	SPARK Precision, SPARK Light, OCULUS Fast Threshold, Full Threshold (4/2), CLIP (Continuous Light Increment Perimetry), age adapted suprathreshold screening (2-zone, 3-zone, quantify defects)
Test patterns	30-2, 24-2, 10-2, hemisphere, quadrant, single test points
Reports	Glaucoma Staging Program (GSP), Progression report Threshold Noiseless Trend (TNT), Glaucoma Staging System 2 (GSS2)
Result display	Grayscale, dB values (absolute/relative), symbols, probabilities, 3D plot
Specifications	
Perimeter bowl radius	r= 30 cm (11.81")
Stimulus size	Goldmann III
Stimulus luminance range / increments	0-3,180 cd/m ² (10,000 apostilbs) / 0.1 log steps
Background luminance	10 cd/m ² (31.4 apostilbs)
Examination speed	Adaptive, fast, normal, slow
Stimulus color	White
Maximum eccentricity	30°
Fixation control	CMOS camera, central threshold, Heijl-Krakau
Patient positioning	Headrest adjustable, double chinrest, moving cone
Device weight with accessories	6,6 kg (14,5 lb)
Electrical operating voltage	All normal voltages from 100-240 V
Interface	USB, RS232/V24, SubD
Hand control unit (optional)	Monitor: Colour LCD display with touch-screen Storage: min. 40,000 examinations, data transfer to PC for backup and networking Printer: Integrated thermal printer
Software	Pre-installed on hand control unit Backup, control, report and print software for Windows®-PC
PC requirements	OS: Windows® XP or higher

CE in accordance with Medical Device Directive 2007/47/EG

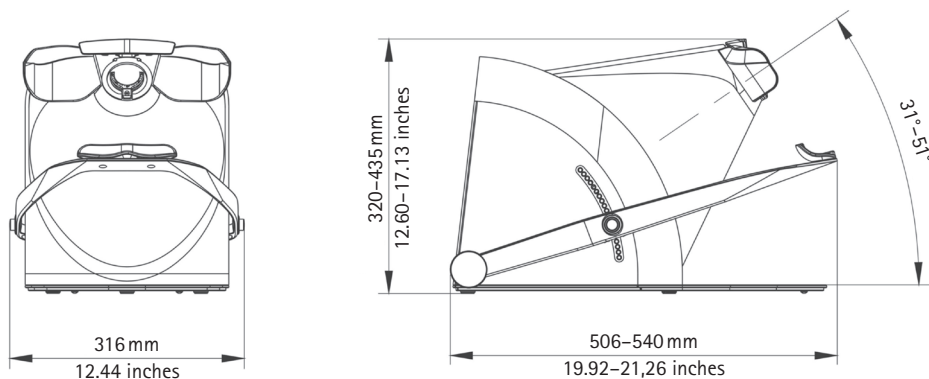

WWW.OCULUS.DE



OCULUS is certified by TÜV according to
DIN EN ISO 13485/DIN EN ISO 9001

OCULUS Optikgeräte GmbH

Postfach • 35549 Wetzlar • GERMANY
Tel. +49-641-2005-0 • Fax +49-641-2005-295
E-Mail: export@oculus.de • www.oculus.de

OCULUS Inc., USA

#112 • 2125 196th Street SW • Lynnwood • WA 98036
Toll free 1-888-284-8004 • Fax +1-425-670-0742
E-Mail: sales@oculususa.com • www.oculususa.com