

# Seeing Eye Health Differently

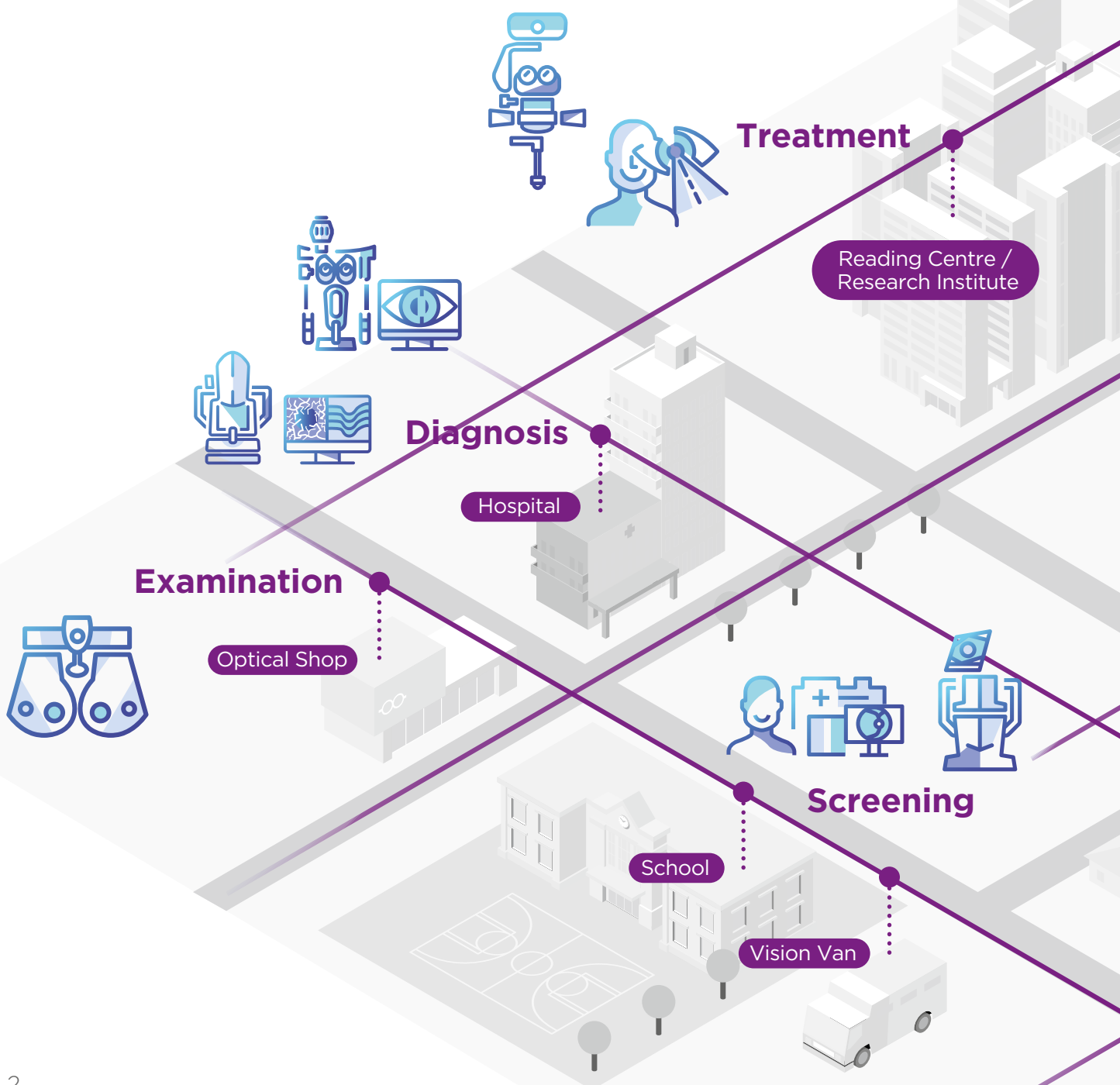

Topcon Healthcare's new focus into preventive medicine and telemedicine, is enhancing the comprehensive solution of unique feature devices and advanced software. We are aiming to provide the different eye care services to improve the customers' and the partners' business.

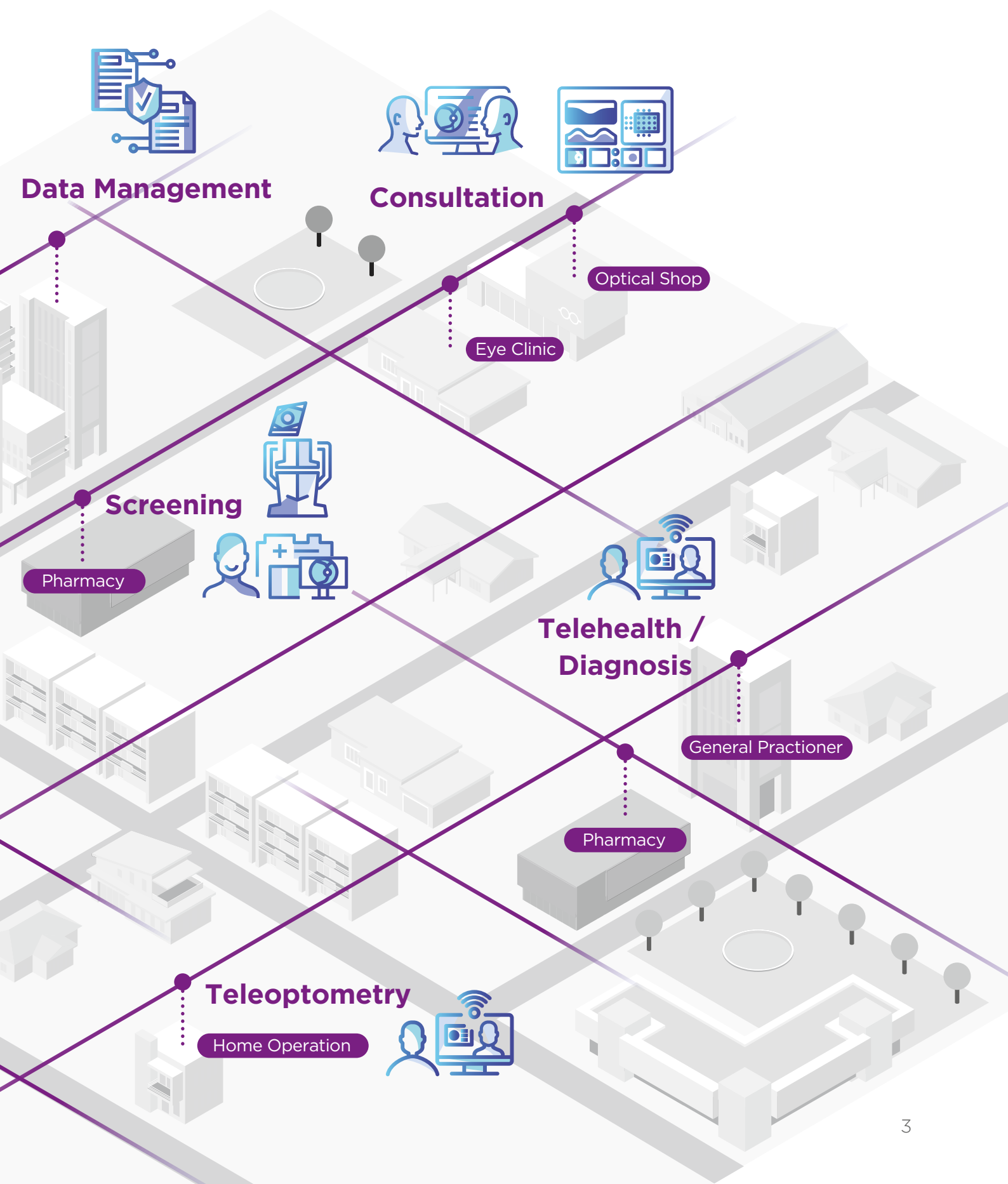



Topcon invests in technologies and solutions to make our customers successful every day.



# Contents

## Optical Coherence Tomography

DRI OCT Triton	6
3D OCT-1 Maestro2	12

## Image and Data Management Solutions

Harmony	16
IMAGEnet® 6	18

## Retinal Cameras

TRC-NW8 Series	20
TRC-NW400	22
Signal*	23
TRC-50DX	24

## Tonometers

CT-1P	26
CT-800A	27
CT-800	28

## Corneal Topographers

CA-800*	30
MYAH*	32

## Biometer

ALADDIN*	36
----------	----

## Visual Field Analyzer

Henson 9000*	40
--------------	----

## Kerato-, Refracto- and Tonometers

TRK-2P	44
KR-800PA	45
KR-1	46
KR-800S	48
KR-800A	49
KR-800 / RM-800	50

## Lens Meters

SOLOS*	52
CL-300	54
LM-8	55

## Slit Lamps and Imaging Solutions

SL-2G	58
SL-D4 LED	59
SL-D701	60
SL-D2	61
SL-D301	62

SL-D4	63
DC-4	64
BG-5	65

## Refraction

Chronos	68
---------	----

## Vision Testers

CV-5000PRO Phoropter	72
CV-5000PRO Controllers	73
VT-10	74

## Chart Systems

CC-100XP	76
CC-100	77
ACP-8EM	78

## Wavefront Analyzer

KR-1W	80
-------	----

## Specular Microscope

SP-1P	82
-------	----

## Operation Microscopes

OMS-800 Series	84
OMS-90	86

## Pattern Scanning Laser

Pascal® Synthesis™ Pattern Scanning Laser*	90
--	----

## Instrument Tables

ATE-800*	94
ATE-700 (PC)*	95
ATE-600* / ATE-650*	95
ATE-300*	96
IC-1*	97
IC-1E*	98

## Instrument Stands and Chairs

IS-1P*	100
IS-1D*	101
IS-1*	102
IS-600 III*	103
IS-100*	104
FS-1*	105

\* 

EC	REP
----	-----

 does not apply to products **not** manufactured by Topcon.

# Discover more possibilities: see beyond and deeper with DRI OCT Triton SS-OCT

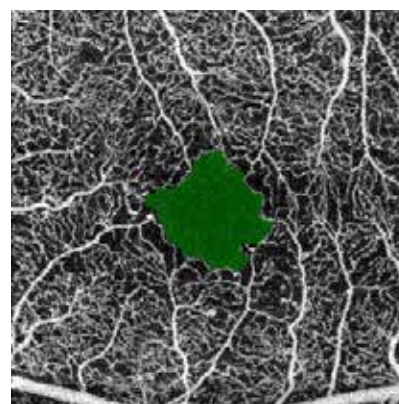
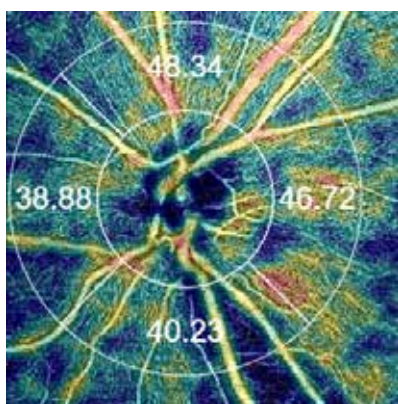
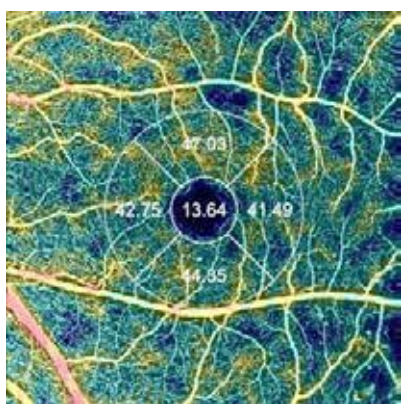

Courtesy: Michael H. Chen, O.D.

## OCTA Tools

Objectively and quantitatively assess retinal vasculature with net OCTA metrics.\*



\* Product feature only available with OCTA. OCTA is optional extra.

# Optical Coherence Tomography

# DRI OCT Triton

## Welcome to the New Frontier in OCT Imaging

The DRI OCT Triton combines the world's first<sup>2</sup> Swept Source OCT technology with multimodal fundus imaging.

### Image Quality

Triton's Swept Source with its 100 kHz scanning speed and 1,050nm wavelength results in clear and detailed images even for the deepest layers of the eye with short acquisition time. Visualize not only the retina and vitreous, but also the choroid and sclera<sup>1</sup>.

### Diagnostic capability

Seeing deeper makes it possible to have a better understanding of many ocular pathologies<sup>1</sup>. With features such as OCT angiography, fundus autofluorescence and en face OCT, Triton empowers clinicians with multimodal imaging capability to help assess and preserve patient's eye health.

### Practice efficiency

The Triton's automated functions, including single scan captures and SMARTTrack™ system, are designed to optimize your practice workflow by simplifying data capture, analysis and follow-up.



1) Fabio Lavinsky, Daniel Lavinsky. Novel perspectives on swept-source optical coherence tomography. Int J Retin Vitre (2016) 2:25  
2) 2015 Comprehensive Report on The Global Ophthalmic Diagnostic Equipment Market



## Discover What Lies Beneath

TOPCON's SS OCT Angio™ combines OCT angiography with a Swept Source OCT.

OCTARA™, a proprietary image processing algorithm, provides highly sensitive angiographic detection<sup>3</sup>, allowing for visualization of vascular structures even in the choroid and deeper retinal layers.

### High-sensitivity Imaging and Deeper Intravascular Flow Visualization<sup>1</sup>

Swept Source technology and OCTARA™ allow the deeper structures to be visualized with less depth-dependent signal roll-off<sup>3</sup>. Additionally, the 1µm wavelength makes OCT Angiography imaging possible for patients with media opacities.

### Rapid Scanning, Real Time Eye Tracking

At 100,000 A-Scans per second coupled with invisible\* scanning lines and the SMARTTrack™ eye tracking system, 'the Triton quickly captures a dense data set and provides an en face OCT Angiography image of the retinal microvascular flow network'<sup>3</sup>.

\* OCT Angiography scanning line may be faintly visible during capture to some people with certain conditions

### Efficiency & Workflow Integration

Multimodal platform provides comparison of microvascular impairment with FA, FAF, OCT and true color fundus images in a single device\*.

\*DRI OCT Triton Plus

12x12mm 512 pixels

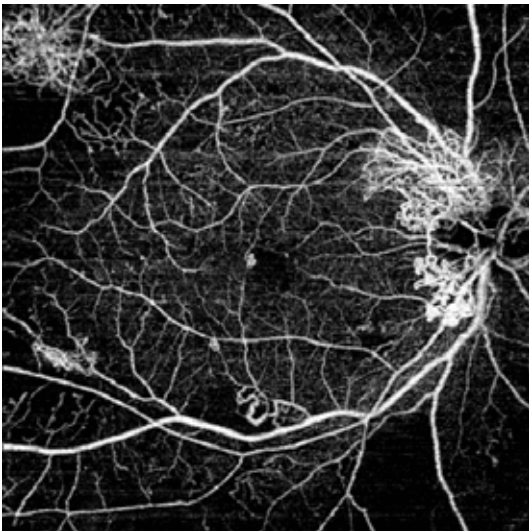

Courtesy: Akihiro Ishibazawa, MD, PhD, Asahikawa Medical University Graduate School of Medical Sciences, Hokkaido, Japan

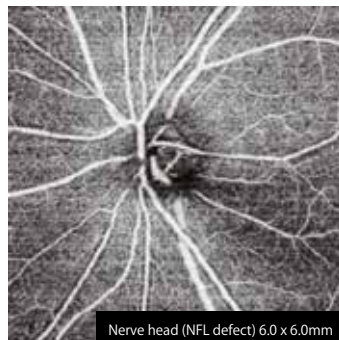

Nerve head (NFL defect) 6.0 x 6.0mm

Courtesy: Kazuya Yamagishi, MD, Hirakata Yamagishi Eye Clinic, Japan

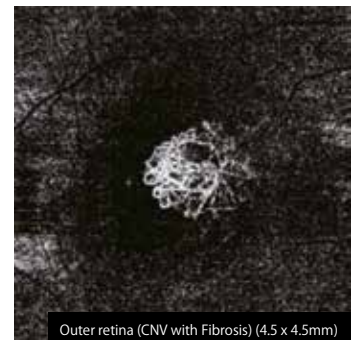

Outer retina (CNV with Fibrosis) (4.5 x 4.5mm)

Courtesy: Dr.Carl Glittenberg, MD, Karl Landsteiner Institute for Retinal Research and Imaging, Austria

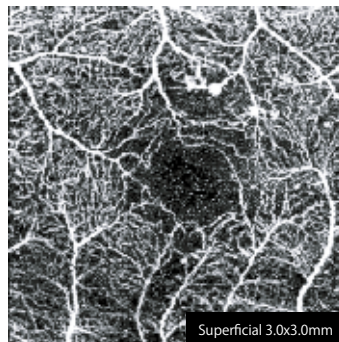

Superficial 3.0x3.0mm

Courtesy: Akihiro Ishibazawa, MD, PhD, Asahikawa Medical University Graduate School of Medical Sciences, Hokkaido, Japan

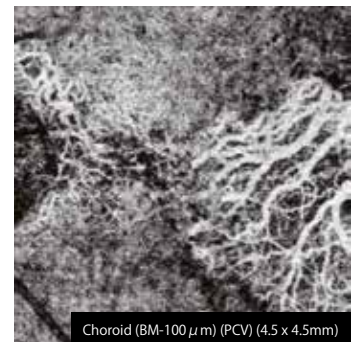

Choroid (BM-100 µm) (PCV) (4.5 x 4.5mm)

Courtesy: Dr.Carl Glittenberg, MD, Karl Landsteiner Institute for Retinal Research and Imaging, Austria

1) Fabio Lavinsky, Daniel Lavinsky. Novel perspectives on swept-source optical coherence tomography. Int J Retin Vitro (2016) 2:25

3) Magdy Moussa, Mahmoud Leila, Hagar Khalid. Imaging choroidal neovascular membrane using en face swept-source optical coherence tomography angiography. Clinical Ophthalmology 2017;11:1859-1869



## DRI Meets Multimodal Fundus Imaging: See the Whole Picture

Swept Source OCT incorporates multimodal fundus imaging

DRI OCT Triton can acquire the OCT and fundus image in a single capture. PinPoint™ Registration identifies the location of the B-scan on the fundus image. Comparison between the B-scan and fundus image can support clinical efficiency during diagnosis.

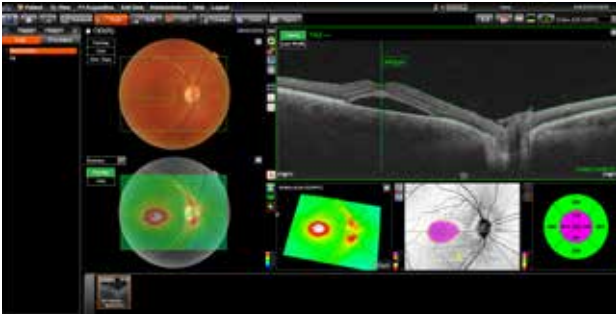

Courtesy: Jay M. Haynie, O.D.

OCT + Color fundus

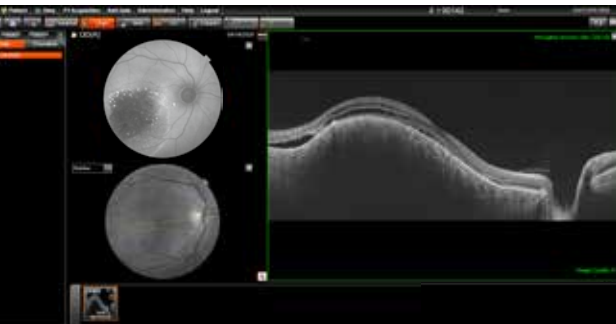

Courtesy: Jay M. Haynie, O.D.

OCT + FAF

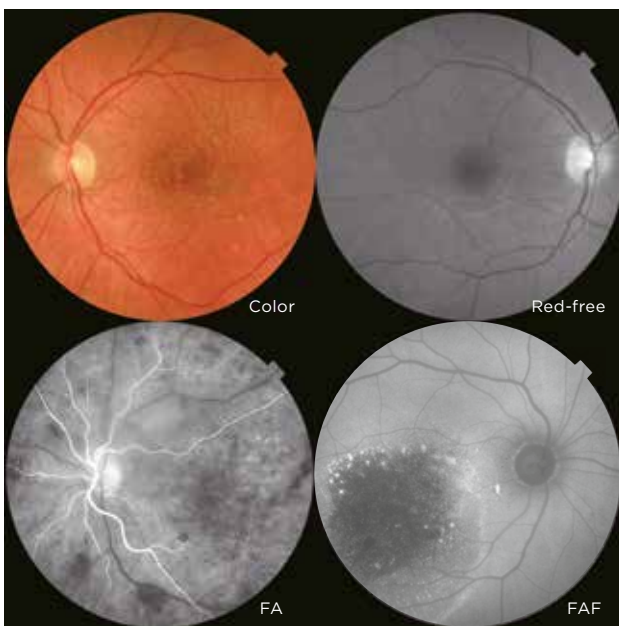

### True color\* Fundus images

The DRI OCT Triton offers a true color, non-mydratic fundus image. Fluorescein Angiography (FA) and Fundus Autofluorescence (FAF) are available\*\* to enhance the diagnostic capability of Triton Plus. The all-in-one device supports efficient workflow in practice.

\* Color fundus image with white light, with 24-bit color.

\*\* DRI OCT Triton Plus :

OCT /Anterior OCT (Option)/ OCT Angiography (Option) /Color Red-Free / FA / FAF

DRI OCT Triton :

OCT /Anterior OCT (Option)/ OCT Angiography (Option) /Color/ Red-Free

## Discover from Cornea to Choroid

### Anterior segment imaging

Triton's (optional) anterior segment imaging capabilities allow for visualization of the cornea, anterior chamber angle, iris and sclera<sup>5</sup>.

Image samples

### OCT image B-scan length 16mm



## Triton with PixelSmart™ is the next stage in Swept Source OCT imaging

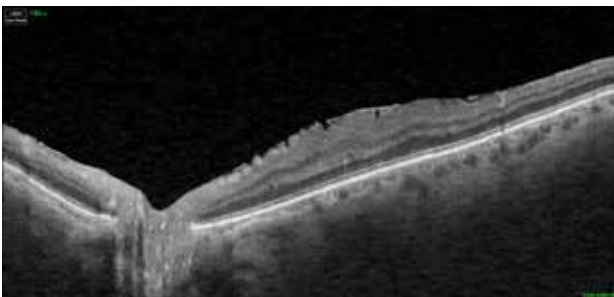
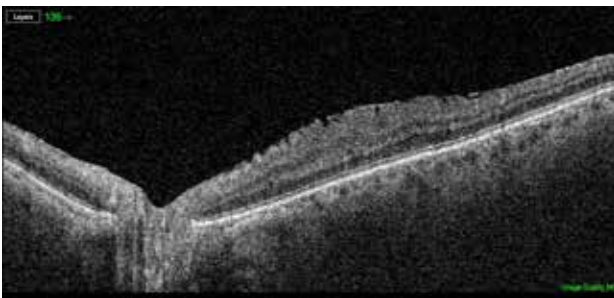

### NEW! PixelSmart™

Triton with PixelSmart.  
The next level in Swept Source OCT Imaging.

PixelSmart is Topcon's new image processing algorithm which reduces speckle noise to improve contrast, producing a better image quality.

PixelSmart is available for all Triton 3D scans, existing and new:

- 3D Wide
- 3D Macula
- 3D Disc
- Combination scans

5) Judyta Jankowska-Szmul, Edward Wylegala. The CLASS Surgical Site Characteristics in a Clinical Grading Scale and Anterior Segment Optical Coherence Tomography: A One-Year Follow-Up. Journal of Healthcare Engineering 2018, Article ID 5909827

# 3D OCT-1 Maestro2



- OCT and true color\* fundus photography
- 50,000 A-Scans per second
- Fully automated image capture
- Compact and space saving design
- 3D wide scan with Hood Report for Glaucoma
- Reference database comparison for full retinal thickness (Retina), ganglion cell + inner plexiform layer thickness (GCL+), ganglion cell complex thickness (GCL++), circumpapillary retinal nerve fibre layer thickness (RNFL)
- Automatic 3D layer segmentation
- Anterior segment OCT
- Panoramic fundus imaging
- 3D volume view

Introducing automated OCT, true color\* fundus photography and automated OCT Angiography in one compact instrument. With the touch of a button, OCTA provides you instantaneous vascular structure information - from our world-renowned, multimodal OCT solution.

## User-friendly

A user-friendly OCT. The Maestro2 uses robotic technology and improves practice efficiency whilst providing optimal patient care.

## Fully Automated Capture

With a single touch, the Maestro2 automatically performs alignment, focus, optimization and capture. After image capture, the report can be immediately displayed by clicking on the icon.

## Manual/Semi-Automatic Capture

In addition to automated capture, the Maestro2 offers manual/semi-auto options for difficult-to-image patients.

**Maestro2 offers RTC**  
(Remote Tablet Control)  
for social distance  
protocol.\*<sup>1</sup>



The breath shield is not part of the Maestro2 product configuration. Please ask your distributor for availability.

\*True, full color fundus image simultaneously captured with white light, 24-bit color.

<sup>1</sup> Applicable distance is subject to the device's communication performance and the communication environment.

# Maestro2 – Now Featuring OCT Angiography

Introducing fully automated  
OCT Angiography\*<sup>1</sup>

At the touch of a button, Maestro2 provides instantaneous vascular flow information without the need for contrast dye injection, together with comprehensive segmentation to enable advanced diagnosis. OCT Angiography includes OCTA Density.\*<sup>2</sup>

Healthy Eye <sup>\*3</sup>

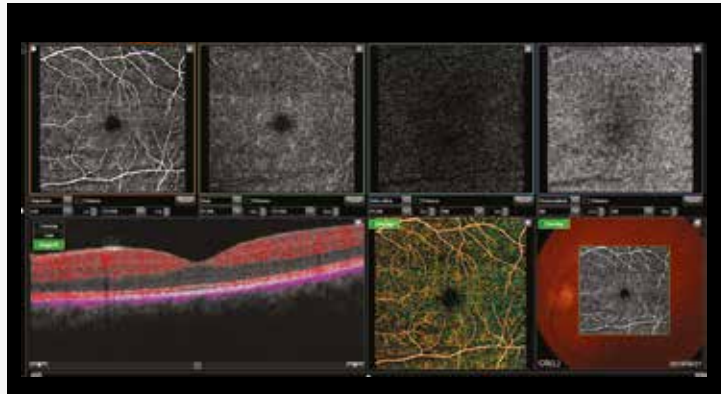

Choroidal Neovascularization (CNV)<sup>\*4</sup>

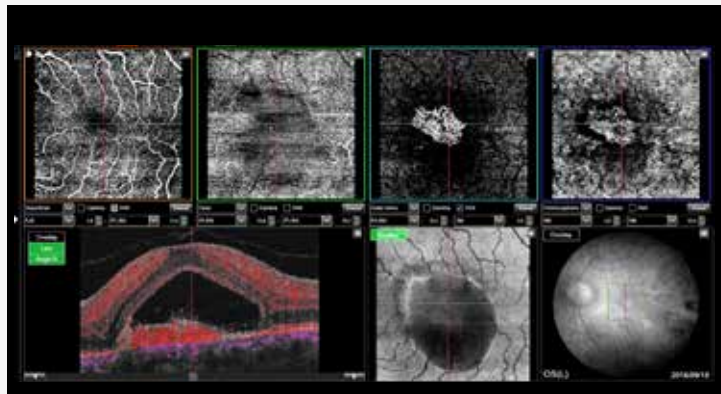

Diabetic Retinopathy (DR) PinPoint™  
Registration of microaneurysms<sup>\*5</sup>

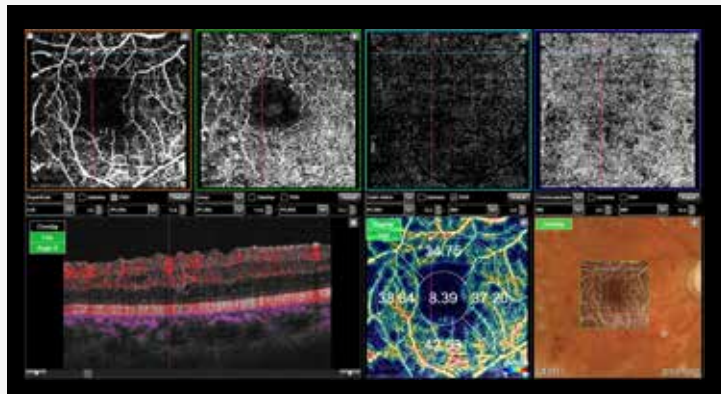

\*<sup>1</sup> OCTA optional extra in some countries. Please check with the distributor in your country.

\*<sup>2</sup> The OCTA Density is defined as the ratio between the high signal area and low signal area and it is displayed in color and/or number.

\*<sup>3</sup> Michael H. Chen, OD

\*<sup>4</sup> Prof. Siamak Ansari Shahrezaei, MD PhD (Karl Landsteiner Institute for Retinal Research and Imaging)

\*<sup>5</sup> Miho Nozaki, MD, PhD (Nagoya City University Hospital)

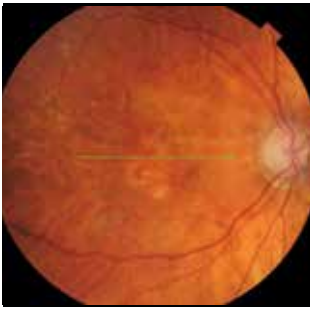

Tracking is used to capture exactly the same area at each visit and is available for single line, radial or 5 line cross scans.

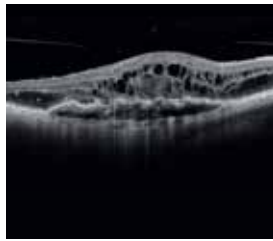

Baseline visit



Follow-up visit

## Follow-Up Scans

For smaller, more localized areas, tracking based on the reference image allows follow-up scans to be performed.

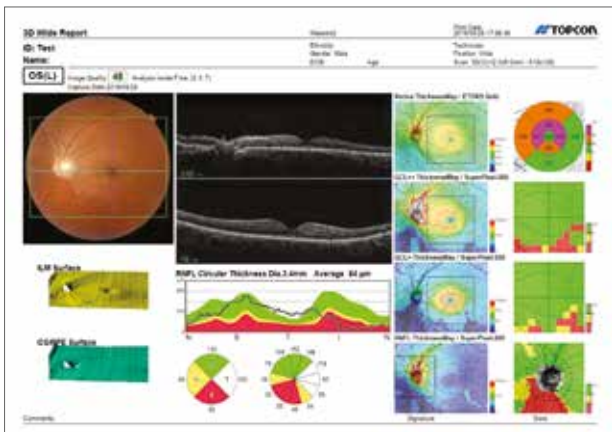

## Widefield OCT Scan

The Maestro2 can capture a 12mmx9mm widefield OCT scan, encompassing both the macula and optic disc. Ideal for an annual eye exam, the scan reduces patient testing time. It provides thickness and reference data for the retina, RNFL and ganglion cell layers together with a Glaucoma report which includes disc topography.

GCL+: The thickness of GCL and IPL

GCL++: The thickness of GCL, IPL and RNFL

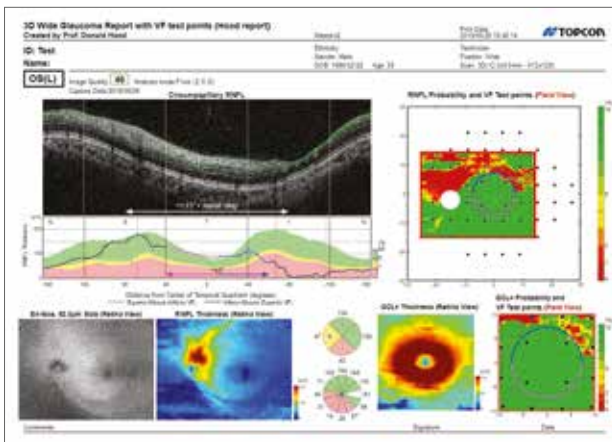

## Hood Report for Glaucoma with Probability Maps with 3D Wide 12x9mm Scan

Retinal Thickness/RNFL/GCL and probability maps, all in one report. The New Hood Glaucoma Report is now available. This innovative report streamlines the decision-making process through the correlation of structure (GCL/RNFL) with function (overlay of visual field test locations).\*

\*Donald C. Hood PhD, Translational Vision Science & Technology No.6 Vol.3 2014: Evaluation of a One-Page Report to Aid in Detecting Glaucomatous Damage.

# Image and Data Management Solutions

# Harmony

Harmony is a web-based software solution that connects all examination instruments, eye care professionals, and latest technologies to ensure the best possible patient care and customer experience.



## TURNKEY SOLUTION. PEACE OF MIND.

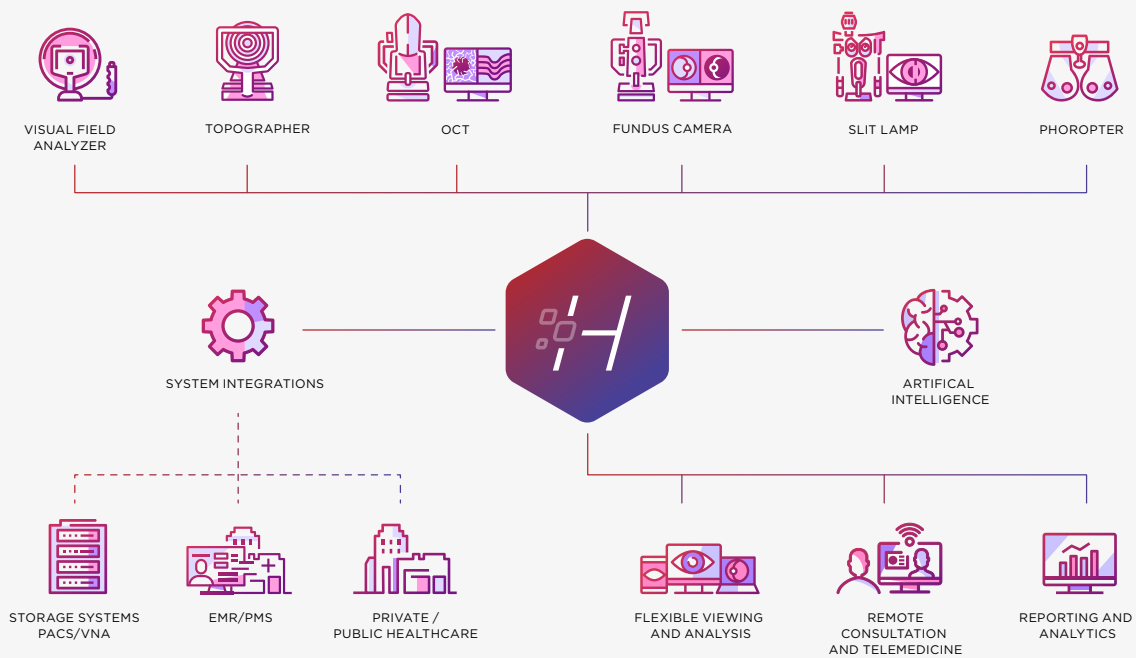



- Eye care professionals to seamlessly access all examination data regardless of the type and brand of the examination instrument, thus allowing fast decisions in patient cases.
- Eye care specialists to work together and securely communicate on patient data, enabling better informed decisions, better and faster care for patients.
- The integration of Artificial Intelligence (AI) algorithms, which assists eye care specialists in earlier detection and diagnosis of eye diseases.
- Helps to increase the efficiency of a busy practice by integrating devices and software into one seamless user experience.
- Enables modern workflows and automated processes to allow high quality of clinical care paths and standardized procedures.

## Features at a glance

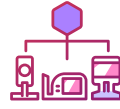

Connects with any device, regardless of device type and brand – DICOM or not.



Browser-based applications, that allow fast access to all patient exam data from any computer, at any time.



Worklist manager, which eliminates time spent entering patient information at the instrument.



Secure medical grade storage system where all data is encrypted and backed-up.



Data analytics and reporting tools to support your clinical and business operations analytics.



Easy to use. Quickly scroll through your OCT, Fundus and other images.

## Additional Features at a glance



Secure telehealth portal for internal and external referrals and second opinions, accessible by accredited specialists from anywhere at any time.



Artificial Intelligence (AI) integrations, that may help early detection and accurate diagnosis in a fast and secure manner.

IMAGEnet software is for acquiring, displaying, enhancing, analyzing and saving images obtained with a variety of Topcon photographic devices, such as OCT, mydriatic and non-mydriatic retinal cameras and photo Slit Lamps.

Topcon refraction instruments such as phoropters, refractometers and lens meters can also be connected. Pre-sets, will improve the refractive workflow.

IMAGEnet has numerous image management functions that facilitates image acquisition, enhancement, measurement and comparison.



# Retinal Cameras

TRC-NW8 SERIES | TRC-NW400 | SIGNAL | TRC-50DX

# TRC-NW8 Series

- Compact, automated versatile camera
- Wide 85° angle of coverage with internal fixation
- 30° & 45° angle available
- Autoshoot, autofocus and auto-exposure: time saving and user-friendly
- Small pupil capability down to 3.3 mm
- Panoramic overview with optional mosaic module
- Stereo photography: easier diagnosis
- IMAGENet connection

The TRC-NW8 series is an impressive line-up of retinal imaging for all vision care professionals. The TRC-NW8 series can capture non-mydratic color images, red-free images and Fluorescein Angiography.

## Ease of use

The autoshoot, autofocus and auto-exposure ensure sharp, clear images with a lot of details. In one movement the practitioner can switch between color, red-free and fluorescein images.



TRC-NW8



TRC-NW8F



### Patient comfort

The low flash intensity offers the patient increased comfort, which enables the practitioner to take more images in less time. A minimum pupil size of 3.3 mm is needed.

#### TRC-NW8

The TRC-NW8 comes with a Nikon digital camera, enabling the user to zoom in on the finest detail. The Topcon TRC-NW8 offers a 45° angle which covers fovea and macula. Nine fixation targets enable to shoot nine images which can be collated into a mosaic, or panoramic overview. Auto Mosaic is an option (IMAGEnet Auto Mosaic is needed for this function). Stereo photography and a real red-free filter is a standard option on TRC-NW8.

#### TRC-NW8F

The TRC-NW8F non-mydratic fundus camera has the same functionality as the TRC-NW8 but adds the possibility to do also Fluorescein Angiography with the same Nikon digital camera.

# TRC-NW400



- Non-mydriatic retinal camera
- True colour fundus images
- Fully automated
- Full 360° rotating monitor
- Rapid and simple capture by single touch
- Small footprint

The TRC-NW400 is an automated and robotic fundus camera that performs true color photography. By incorporating the 360° rotating touch panel monitor, the operator is able to acquire the image rapidly and easily by a simple finger touch. It makes your workflow efficient.

### Space Saving

The TRC-NW400 incorporates a rotating touch panel monitor that allows the operation of the instrument from virtually any angle. This feature lets the operator be in front, behind or at either side of the patient, optimizing space saving. The TRC-NW400 can comfortably be operated when located against a wall or in a corner.

### Internal Fixation Target Operation

The Traditional 3 fixation targets (Disc, Center and Macula) as well as the 9 fixation target for peripheral photography are incorporated.

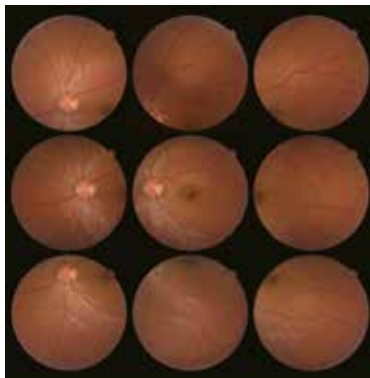

9 Fixation Target



D C M

### Small Pupil Photography & Zoom Function

The TRC-NW400 enables the user to acquire retinal images with pupils  $\Phi 3.3\text{mm}$  or more, assisting functions as small pupil aperture, digital zooming function and overlaid mask. When the "small pupil mode" is selected, the camera will automatically adjust for small pupils\*.

### Anterior Photography

Anterior photography function allows for quick documentation of external conditions of the eye surface and cornea.



Anterior Image

Courtesy: New York Eye and Ear Infirmary of Mount Sinai NYC



\*Details depend on setting

## Imaging Modalities



### True Color Fundus

True color fundus images are the gold standard in fundus photography, examining the fundus in full color.



### Red-Free

Red-Free images provide an enhanced visual contrast of anatomical details of the fundus.



### Infra-Red

The invisibility of IR light makes it more acceptable for imaging children and light-sensitive patients. As the penetration of IR light is better, it acts as a useful imaging tool in patients with media opacities like dense cataract. IR can help to visualize external layers (choroid vessels) as well.



### Low-Red

Low-Red is a different color rendering of the standard color image and can be useful in some cases if the eye care specialist is used to working with other cameras with more green or orange color rendering.



The Signal hand-held retinal camera, is a versatile addition to the Topcon Imaging line. The Signal is a mobile imaging solution for use in different exam rooms or home settings. The Signal hand-held retinal camera offers true color fundus images for detailed retinal examination.

## Imaging

The Signal enables non-mydratric retinal examination with a 50° x 40° field of view, covering the macula and the disc. It is not necessary to dilate pupils. True color images and videos offer excellent screening and documentation of the retina. The nine fixation targets offer both central and peripheral imaging.

## Portability

The Signal is ultra-lightweight, compact and comes in a smart carry case. The eye care specialist can visit bedridden patients in nursing homes, or at their own home. The Signal has an operating time of approximately 2.5 hours of continuous use. Images can be uploaded if WiFi is available or can be stored on the Signal embedded memory.

## Ease of Use

The auto-focus function of the Signal ensures easy and fast image acquisition. In combination with the Topcon Slit Lamp adapter, positioning and alignment becomes even more effortless. Intuitive icons give access to easy to use menu options in the camera.

## Flexible and Mobile Acquisition

Some patients are difficult to capture with a stationary retinal camera. The maneuverability of the Signal makes it easier to take images of an un-cooperative patient. The invisible IR light source does not distract the patient due to the low brightness and intensity and is more acceptable to children and light-sensitive patients. Elderly patients can be screened easily in a reclined or lying down position.

## Slit Lamp Mount

A Slit Lamp is a standard instrument in most clinics. The Signal can be quickly and easily mounted to a Slit Lamp, adding fundus imaging to the patient workflow.

- High Quality Fundus Image
- Multimodal Fundus Imaging (Color, Red-free, FA, FAF<sup>1</sup> and ICG<sup>1</sup>)
- Mydriatic Retinal Camera
- Comprehensive Fundus Imaging Tool
- High Resolution Imaging Sensors
- Connect with IMAGEnet® 6
- Flash Intensity Control
- Working Distance Dots

Rapidly developing technical advancements in digital cameras has led to retinal imaging with higher resolutions and newer capturing methods. Topcon's TRC-50DX retinal cameras incorporate state-of-the-art sensors that enhance versatility, image quality and operational ease. The TRC-50DX offers multimodal fundus imaging including color, red-free and fluorescein angiography (FA) while the TRC-50DX (Type IA) can also perform indocyanine green (ICG<sup>1</sup>) and fundus autofluorescence (FAF<sup>1</sup>).

### Fundus Autofluorescence

Fundus autofluorescence (FAF<sup>1</sup>) is a non-invasive technique to acquire images of the retina by visualizing the autofluorescence of lipofuscin within the retinal pigment epithelium (RPE). The Topcon-exclusive, Spaide FAF filters<sup>2</sup> are optimized for the observation of lipofuscin deposits in the retina as they require 40% less illumination than conventional FAF<sup>1</sup> filters<sup>3</sup>. As an added benefit, Spaide filters do not stimulate fluorescein or ICG<sup>1</sup> and images can be taken during or post-angiography.

### Easy to Operate

An intuitive, touch-screen control panel simplifies its use, allowing the operator to better concentrate on the patient. Ergonomically located adjustment knobs make the capture process effortless and comfortable.

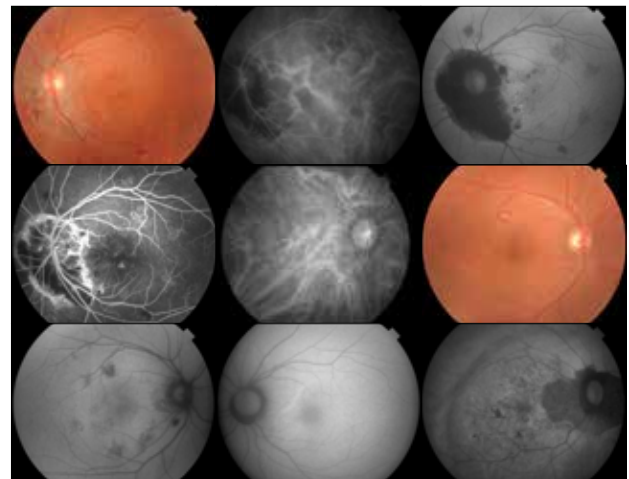

Image courtesy of Adachi Keiyu Eye clinic, Japan.

1. FAF and ICG are only available on the TRC-50DX (Type IA)  
 2. Richard F. Spaide, MD, Vitreous Retina Macula Consultants of New York.  
 3. "Optimized Filters for Fundus Autofluorescence Imaging" Reviewed by Richard Spaide, MD - Retina Today - April 2009.



# Tonometers

# CT-1P

- Fully automated operation with touchscreen
- Reliable & fast measurements
- Flexible & space saving layout
- Soft air puff
- Adjusted IOP calculation

The CT-1P non-contact tonometer takes automated operation to another level. Simply touch the centre of the pupil on the touchscreen control panel and the CT-1P automatically measures the intraocular pressure (IOP) and the pachymetry for both eyes.

All operating procedures can be performed with the rotatable touchscreen, the sophisticated buttons provide an intuitive experience. The soft air puff used for measurement leads to less stress for the eye and more comfort for the patient. The CT-1P calculates the adjusted IOP based on measured pachymetry to obtain reliable IOP measurements according to the actual thickness of the cornea.

The adjustable control panel allows the operator to position him- or herself anywhere around the patient since the modern touchscreen panel can be positioned in several directions. This makes the CT-1P a flexible and space saving instrument.



- 3D Auto alignment function allows quicker & easier measurement
- Smooth operation
- 8.5 inch wide touchscreen control panel
- Soft air puff
- Higher measurement success rate for eyes with IOL, in the IOL measurement mode
- Compensated IOP values with central corneal thickness values
- Compact designed body
- Easy set-up with a LAN network

Topcon has significant experience in designing and producing high quality tonometers and kerato refractometers. For a greater customer experience, Topcon has developed the CT-800A, a non-contact tonometer with 3D auto alignment function. CT-800A offers enhanced efficiency and easier operation to improve the day to day examination and the work flow in a practice.

### Adjusted tono value\*

The CT-800A is able to calculate adjusted tono value from a measured IOP to manually by putting corneal thickness value measured by other devices, such as a pachymeter.

### Soft air puff

Software controls the optimal amount of air required for every measurement on each individual eye. A soft air puff means less stress on the eye, resulting in an improved patient experience.



\*Adjusted tono value is reference value

- Soft air puff
- Maintenance free air-intake system
- Calculation of adjusted IOP based on pachymetry values
- 8.5 inch LCD touchscreen panel
- LAN connectable
- Easy to use

The CT-800, non-contact computerized tonometer makes intraocular pressure (IOP) measurement easier than ever before. The bright 8.5 inch touchscreen ensures control of all functions just by a touch of a fingertip.

The smooth base movement due to a 23% reduction in weight from the previous models and an improved joystick operation makes the CT-800 easy to use. The soft air puff ensures accurate measurement results which can be printed through the drop-in printer at the front or exported through a LAN connection. The air intake system results in less maintenance and guarantees accuracy. The CT-800 is able to calculate adjusted intraocular pressure based on the manual input of pachymetry values. The compact footprint and design of the CT-800 saves space and adds functionality to the contemporary eye care practice.



# Corneal Topographers

- Topography Map, Corneal Wavefront (Zernike) Analysis
- Contact Lens Fitting Simulation
- Keratoconus Screening
- Tear Film Breakup Tear Meniscus Height/Blink Analysis
- White to White Measurement
- Meibomian Gland Analysis
- Comparison Map, Differential Map, Corneal Height Map
- Pupillometry
- PC Integrated, Space Saving

## Acquisition

The CA-800 is easy to use. Visual signals support fast and easy alignment and accurate focusing. The CA-800 has Right and Left eye detection, preventing incorrect filing of data to the wrong eye. The automated best image selection mode in the CA-800 software, selects the best focused position and automatically acquires the image.



## Pupillometry, fluorescein & meibography

The CA-800 is a placido-based topographer with 24 rings that measures up to 6,144 data points, with axial and instantaneous curvature evaluation. Moreover, it is equipped with four infra-red LEDs and two white LEDs for dynamic and static pupillometry and eight blue LEDs for fluorescein images and videos to carry out full contact lens analysis. With the four infra-red LED's meibomian glands can easily be analyzed for any possible defects.



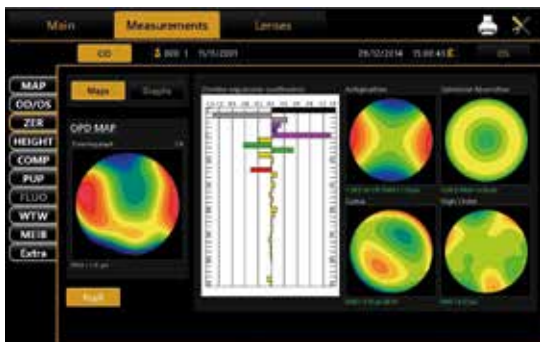

### Corneal Zernike analysis

The Zernike analysis module provides 36 polynomials up to the 7th order, giving a clear view of the optical aberrations which can disturb vision. Based on this information, the CA-800 simulates the effect on vision, which is useful for educating patients about their condition. The pupil size can be selected to examine the implications of the corneal aberrations under different light levels.



### Keratoconus screening

With the CA-800, signs of corneal asymmetry of the cornea can easily be detected even at an early stage. By analyzing various characteristics of the corneal shape, a keratoconus probability index is calculated, with color coding to indicate the level of compatibility of each metric with keratoconus.



### Contact lens fitting simulation

The CA-800 provides a comprehensive platform to optimize contact lens fitting. On-board simulation software automatically selects the best fitting contact lens based on an internal contact lens database for all the main manufacturers (upgradable and customizable by the user). Lens parameters and position can be modified, and the resulting fluorescein simulation saved to a library, to allow rapid comparison between lens options. This minimizes the number of lenses that need to be trialed on the patient's eye, saving time and making the process more acceptable for the patient.



### Blink analysis

The blink analysis function records normal blinking over a period of time to automatically calculate the average blinks per minute and inter-blink interval. Combining this data with the non-invasive tear breakup measurement allows the Ocular Protection Index (OPI) to be calculated, identifying eyes at risk of ocular surface damage.

### i-MAP for CA-800

The optional software i-Map enables delegation of acquisition to support staff while the clinician reviews the data in another room. i-Map allows full manipulation of the data. It contributes to optimizing your clinical workflow.

Build, Manage and Grow Your Myopia & Dry Eye Practice.

## Overview of MYAH



Corneal Topography including keratoconus screening and pupillometry



Axial Length measurement by Optical Low Coherence Interferometry



Progression reports for analyzing treatment efficacy



Comprehensive suite of Dry Eye assessment tools



Patient-friendly with rapid capture



Compact, space-saving, easy to operate

50% of the world's population<sup>1</sup> may be myopic by 2050. **European regions are not an exception.**

Region	2000	2010	2020	2030	2040	2050
Central Europe	20.5%	27.1%	34.6%	41.8%	48.9%	54.1%
Eastern Europe	18.0%	25.0%	32.2%	38.9%	45.9%	50.4%
Western Europe	21.9%	28.5%	36.7%	44.5%	51.0%	56.2%
Global	22.9%	28.3%	33.9%	39.9%	45.2%	49.8%



1. Holden, BA, Fricke, TR, Wilson, DA et al. Global prevalence of myopia and high myopia and temporal trends from 2000 through 2050. *Ophthalmology*. 2016; 123:1036-42. Available from: doi: DOI: 10.1016/j.ophtha.2016.01.006



**Build your Myopia Management Service**  
MYAH provides the initial baseline to monitor risk, allowing you to start the conversation early with parents.

**Manage: Monitor and Compare**  
MYAH provides essential information to monitor eye elongation and compare axial length measurements with built-in growth curves.

**Grow your Myopia Management Service**  
Offering axial length screening tests may complement your refraction tests.

MYAH offers all the technologies required to support myopia management: optical biometry, corneal topography and pupillometry – it is a one-time investment. In addition, MYAH is an all-in-one device that offers an evolving platform which provides the tools to add or grow Dry Eye Management.

## NEW! Introducing MYAH's Growth Curves.

MYAH allows you to monitor the progression of myopia and compare measurements with the growth curves for axial length.

The majority of myopic eyes become myopic principally because of excessive axial elongation<sup>2</sup>. By using the

extensive axial length dataset collected by Erasmus University (Rotterdam, NL)<sup>3</sup> now incorporated in MYAH, you can monitor axial length and then compare the patient's data with normative growth curves. Therefore, you will be able to better understand a child's risk of myopia in adulthood.

## You can now enhance your myopia management with MYAH's growth curves.



Parents/guardians tend to be familiar with growth charts in relation to their child's height and weight as a baby, making it easier to communicate with the parents of myopic children. That is particularly important for pre- and low myopes, where the urgency of intervention is difficult to appreciate based on refractive error alone.



2. (Gifford KL, Richdale K, Kang P, Aller TA, Lam CS, Liu YM, Michaud L, Mulder J, Orr JB, Rose KA, Saunders KJ, Seidel D, Tideman JW, Sankaridurg P. IMI - Clinical Management Guidelines Report. Invest Ophthalmol Vis Sci. 2019 Feb 28;60(3):M184-M203.).  
3. Coordinates incorporated in this Myopia device are the most recent available data and originate from the Myopia Research Group of Erasmus MC, Rotterdam

### Additional Features.

#### Dynamic Pupillometry

Provides clear information on the reaction time and size of the pupil, which may be useful to monitor low dose atropine compliance or to titrate the dose of atropine. The user can examine pupil centration and diameter over a range of light levels, which is useful for Ortho-K and multifocal lens fitting, and is also informative for pre and post-refractive surgery.



#### Contact Lens Fitting

MYAH provides support for contact lens fitting, reducing the number of lenses that need to be trialed on the eye:

- Includes a database of conventional RGP and Ortho-K lenses.
- Export topography data to 3rd party calculators.
- Fluorescein simulation with ability to save and review data.



#### Dry Eye Assessment Tools

These tools offer non-invasive Tear Break-up Time (NIBUT), Meibomian gland imaging with the area of loss analysis, tear meniscus height analysis, blink analysis, real fluorescein imaging and video acquisition, and video review of anterior corneal aberrations between blinks.

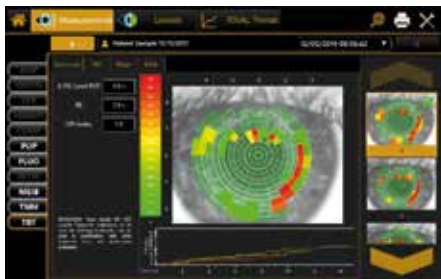

#### Corneal Topography

MYAH offers another range of tools to analyze the anterior cornea, including topographic maps, 3D maps, comparison maps, height maps, Zernike analysis and keratoconus screening.



#### Corneal Aberration Summary

The Zernike expansion coefficient is used to determine which component(s) dominate the aberration structure of the cornea and to what degree.

The anterior corneal Zernike summary consists of 36 polynomials up to the 7th order and provides a clear view of the optical irregularities that can impact the quality of vision.

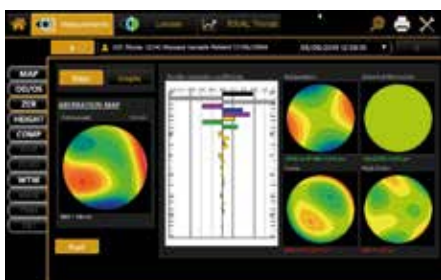

# Biometer

# ALADDIN

The Aladdin is an easy-to-use, combination optical biometer and full corneal topographer. 9-in-1 features include optical coherence biometry, Placido topography, wavefront analysis of the cornea, IOL calculation suite, pupillometry, DICOM connectivity and the NEW RX/AL Trends Module.

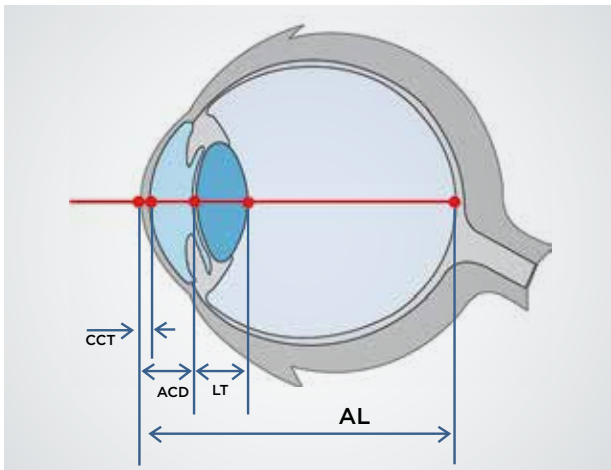

## Posterior & Anterior interferometry

Biometry results are complemented with anterior topography, Zernike analysis and pupillometry in one fast, accurate and easy acquisition. The Interferometer of ALADDIN also provides anterior measurements such as the Central Corneal Thickness (CCT), Anterior Chamber Depth (ACD) and Lens Thickness. You get the complete picture for all cataract surgeries. Whether you are performing standard cataract surgery or premium IOL implantation, you will be screening for corneal aberrations, Keratoconus\* and previous corneal refractive surgery procedures all at once. The ALADDIN only requires just one Acquisition.



## RX/AL Trends Module

- Measures and displays trends in AL changes
- Allows you to monitor change progression
- Charts and tracks refractive variations
- Provides comprehensive printouts

## Aladdin HW3.0



The Aladdin's Barrett IOL Calculation Suite includes the Barrett Rx, the Barrett Toric Calculator Formula, the Barrett True K and the Barrett Universal II formulae.

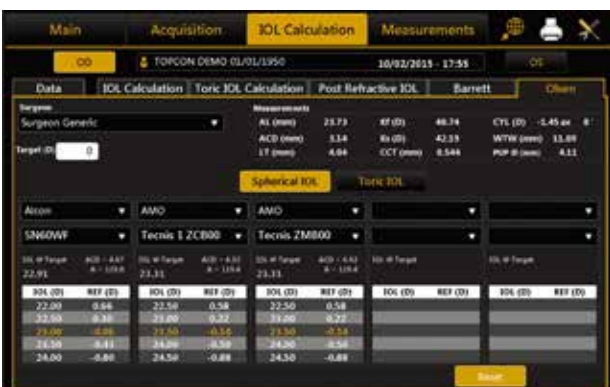

Olsen Formula

## Trend Monitoring

By combining manually entered refractive information with biometric data obtained by low-coherence interferometry, the Aladdin provides a quantitative report of the progression of changes in the eye's refractive power. After the refraction values are entered, the Aladdin performs 7 critical measurements and provides a numerical analysis of the trends of the eye parameters related to changes in the axial length, corneal curvature, anterior corneal wave front analysis and other dimensional variations. Changes can be followed in periods of 3, 6 and 12 months providing a trend that can be used to track the progression of certain eye conditions.

## Onboard Barrett IOL Calculation Suite

Dr. Graham D. Barrett developed the Barrett formula in 2013 and takes into account the posterior cornea considering the lens position for each individual patient instead of calculating IOL power by estimating lens thickness based on patient's age. The Barrett formula uses the Universal II, which is a method of predicting IOL power to work out where the lens is and utilizes that information to calculate the effect of the cylinder power at the cornea. The Universal II formula was also developed by Dr. Barrett. Dr. Barrett's formula considers the thickness and shape of the lens as well, which provides a more sophisticated way of predicting and translating the cylinder power. The formula is able to predict posterior corneal curvature without actually measuring it.

## Onboard Olsen Formula

The Aladdin HW3.0 provides precise measurements of the internal structures of the eye including Central Corneal Thickness and Crystalline Lens Thickness. Those measurements used in combination with the on-board Olsen IOL calculation formula provides accurate IOL power calculations in virtually all types of eyes regardless of size. The Olsen formula utilizes a newly developed concept by Dr. Olsen called the C-constant which predicts the Effective Lens Position (ELP) when performing in-the-bag IOL implants. This model also predicts the lens position of anterior chamber IOLs. The C-constant approach performs independently of other conventional measurements such as axial length, keratometry, white-to-white length, IOL power, etc. It will provide accurate IOL calculations in any type of eye.

KERATOCONUS		KERATOCONUS		KERATOCONUS	
AK	43.03 D	AK	46.75 D	AK	55.06 D
AGC	0.90 D/mm	AGC	1.89 D/mm	AGC	5.39 D/mm
SI	-0.50 D	SI	0.58 D	SI	3.82 D
Kpi	0%	Kpi	70%	Kpi	90%
Topography not compatible with keratoconus		Suspect keratoconus		Topography compatible with keratoconus	

## Aladdin Features.

- Keratometry / Topography
- Keratoconus screening
- Pupilometry
- Aberrometry analysis (Zernike)
- Axial length
- Anterior biometry
- White to white

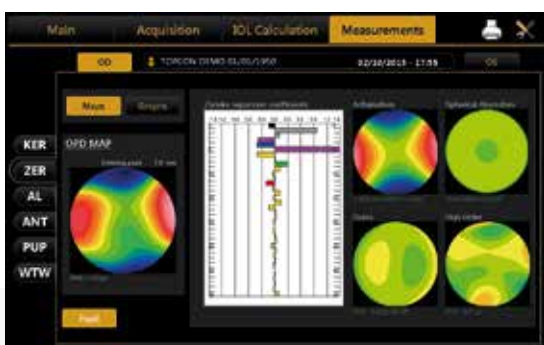
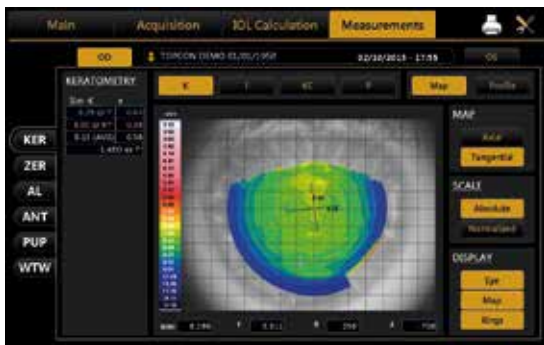

# Visual Field Analyzer

# Henson 9000

## Advanced Detection and Monitoring of Visual Field Loss



The Henson 9000 offers a range of tests for the detection and monitoring of visual field loss along with a full suite of analytical tools and networking capabilities.\* Our commitment to innovation ensures that we can respond to the latest research to provide a perimeter that always benefits you and your patients.

### Smart Supra

Smart Supra was uniquely developed in response to research which showed that 24-2 test patterns miss a large number of early field defects<sup>1</sup>. Smart Supra can be extended beyond its 24-2 pattern with an additional 32 test locations in the central 10 degrees in a 3.5 minute test. Its standard 26 point screening test can be completed in less than one minute.\*\*

### Flexibility for operator and patient

Minimizing confusion and response errors for older patients, while offering enhanced test speed for low risk ones, multiple stimulus is often a patient's preferred choice and can be completed in under 30 seconds; single stimulus is also available for fully-automated testing.

### ZATA

Our alternative to SITA, ZATA can start a threshold test from prior patient data. It uses smart threshold-related terminating criteria to optimize test performance and includes powerful tools for analyzing progression. Tests (24-2) can typically be completed in as little as 2.5 minutes per eye,\*\* providing clear benefits to operator and patient alike.

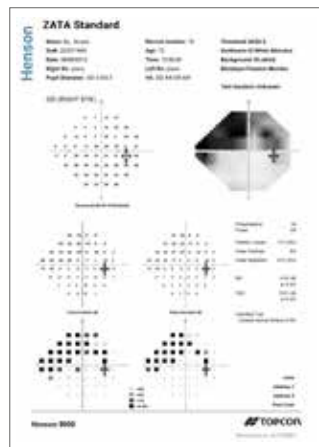

\* Networking capabilities are provided by the controlling computer.

\*\* Test times are approximations only and will differ according to patient response time and level of loss.

<sup>1</sup> De Moraes CG, Hood DC, Thenappan A, Girkin CA, Medeiros FA, Weinreb RN, Zangwill LM, Liebmann JM. 24-2 Visual Fields Miss Central Defects Shown on 10-2 Tests in Glaucoma Suspects, Ocular Hypertensives, and Early Glaucoma Ophthalmology. 2017 Oct;124(10):1449-1456. PMID: 28551166



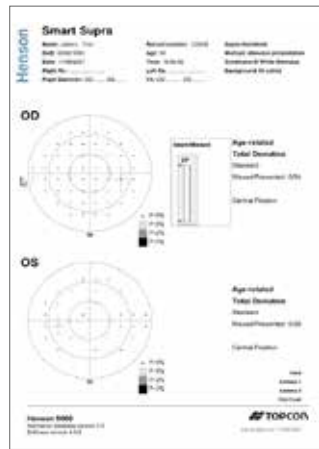

Smart Supra printout

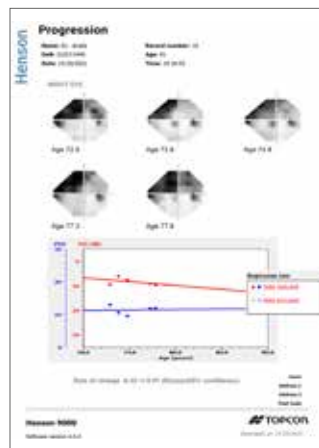

ZATA Progression printout

### Supporting operator efficiency

Our intuitive user interface with context-sensitive help supports ease-of-use for all staff and reduces training requirements. Operators also benefit from fast, easy, single-click access to the Henson Windows-based database.

Benefit from low maintenance costs - robust, solid-state electronics with degradation free light sources ensure the maintenance costs for your Henson 9000 are minimal year-on-year.

### Improving patient experience

The unique facility to re-test locations, add new locations or extend tests, without having to start from scratch, not only supports operator efficiency but improves specificity and reduces false positive test outcomes.

### Compact design

The ergonomic, relatively small size of the Henson 9000 is ideal for space-constrained environments and allows for flexible positioning in any consulting room.

### More as standard

Full facilities for networking, linking to practice management systems and importing and exporting historic patient data are all available as standard.\*\*

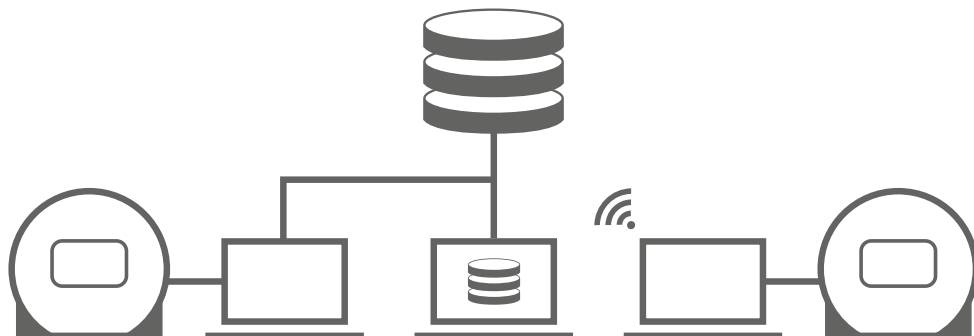

Full facilities for networking available as standard \*\*

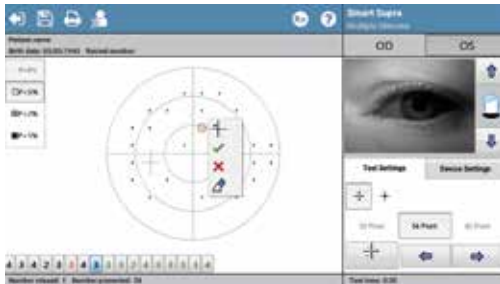

The ability to add/re-test points during Smart Supra tests reduces false positives and improves spatial mapping

Henson Smart Supra can auto-extend from 26 points to 54 points (24-2 pattern) and manually extend further to include an extra 32 points in the central 10 degrees (total of 86 points), while ZATA can extend from the 24-2 to the 30-2 test pattern.

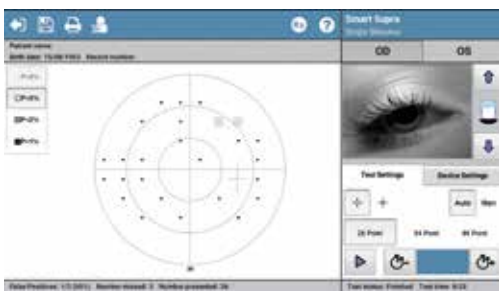

Step 1

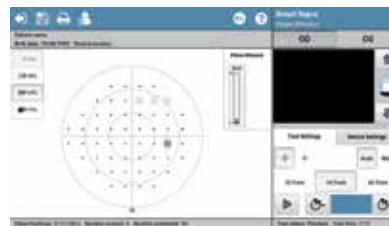

Step 2



Step 3



ZATA uniquely starts threshold tests for existing patients using values from the most recent ZATA test in the Henson 9000 database

# Kerato-, Refracto- and Tonometers

# TRK-2P (with optional LU-1)

- 4in1 Advanced Pretesting Station
- Refractometer, Keratometer, Non-Contact Tonometer and Pachymeter in one single instrument
- Fully automatic
- Rotating touch screen control panel
- Compact and modern design
- Optional LU-1

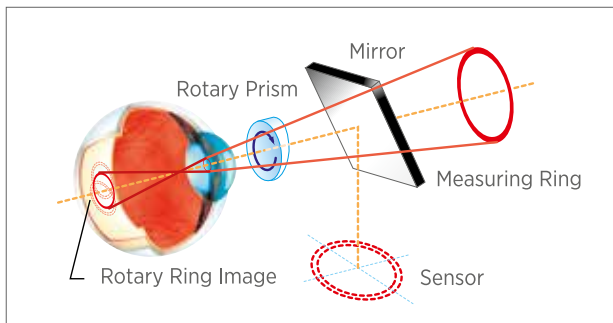

The TRK-2P features a complete Auto-Alignment system, combined with Auto-Refractometer, Keratometer, Non-Contact Tonometer and Pachymeter in one instrument. The rotating touch screen control panel offers total flexibility for the operator and instrument location. The TRK-2P is compact, yet it offers increased performance and cost savings, to optimize efficiency.

## Cataract mode

The cataract mode is available on the automatic and manual setting. This is intended to assist measurement of patients who have cataract or other media opacity, by increasing the exposure.

## Rotary Prism Technology

With Rotary Prism Technology, the TRK-2P provides stable measurement. The unique eccentric rotation of the measurement ring is designed to decrease any artifact from the fundus.

## Pachymetry and IOP Measurements

The built-in pachymetry function assists the practitioner in evaluating the IOP related data. The calculated IOP value can be corrected if the cornea is thinner or thicker than the average. The integrated formula for IOP compensation can be customised by the end user based on the latest clinical research.

## LU-1

The LU-1 control lever accessory adds manual joystick control for users who prefer it.



- Corneal mapping function
- Topcon's Rotary Prism Technology for Unparalleled Accuracy
- Easy operation with 3D auto alignment
- Compact design
- Wide touchscreen control monitor
- Simple and intuitive data display

Topcon offers the unique combination of Kerato-Refractometer and a Corneal mapping system in one device to improve the workflow in your practice. The KR-800PA provides you the most reliable and accurate corneal analysis by making use of the placido ring and its sophisticated measurement principle. It includes Topcon's patented Rotary-Prism technology for quick and precise refraction and keratometry measurements.

Corneal mapping system supports contact lens fitting and diagnosis of corneal irregular astigmatism. It provides information about the shape of the cornea and is displayed quickly and even overlays the mapping output onto the anterior segment by one single touch. Topcon's KR-800PA is an affordable choice for all clinics offering refraction and contact lens fitting. For easy operation and speedy measurement in your practice, the KR-800PA features 3D auto alignment and an Auto-Start function. As soon as the instrument is properly aligned, this innovative function initiates the measurement process and completes multiple readings of each eye.

### i-Map for KR

The KR-800PA comes with i-Map for KR external visualization software for detailed corneal analysis. The software is able to analyze corneal data acquired by KR-800PA remotely. With the i-Map for KR, you are able to make a comparison between multiple exams. i-Map for KR is also a perfect platform for efficient RGP contact lens fitting. The contact lens simulation feature automatically selects the best fitting contact lens based upon the integral, comprehensive contact lens database, featuring all main manufacturers. The Zernike analysis module consists of 36 polynomials up to the 7th order, and provides clear view of the optical deficiencies which can disturb vision.

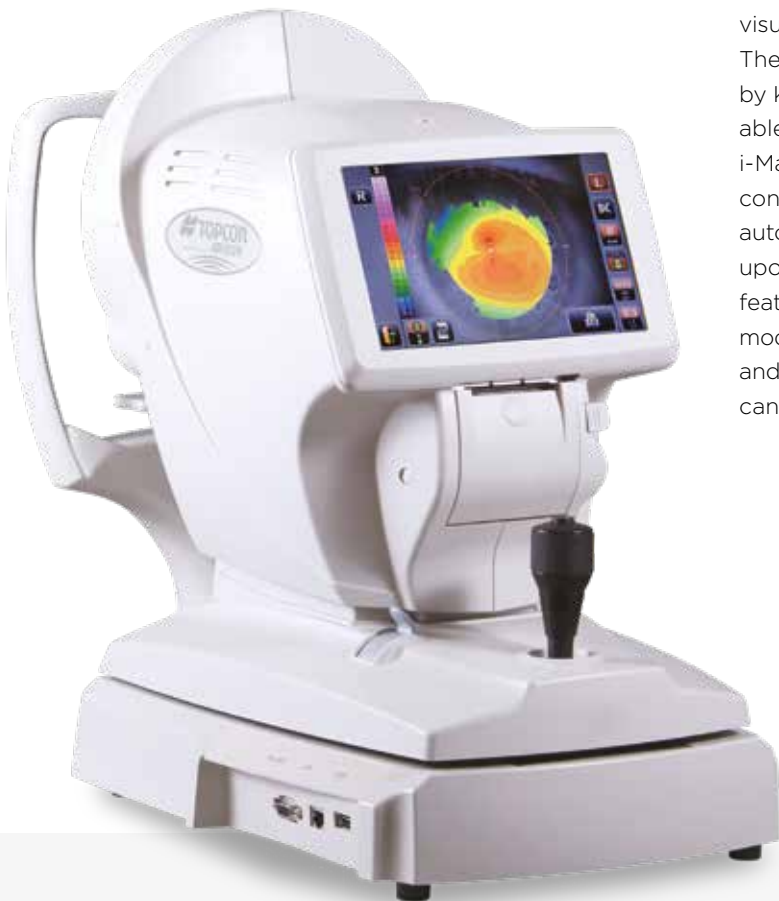

# KR-1

- Fully Automated Kerato-Refractometer
- Rotary Prism Technology
- Full 360° rotating monitor allows operator to maintain distance from patient
- Small footprint. Space Saving
- Patient Friendly
- Easy to use

The Topcon KR-1 is a modern, automated, easy-to-use kerato-refractometer. Controlled from the color touchscreen and incorporating Topcon's Rotary Prism technology.

## Flexible and Space Saving Layout

The control panel can be rotated in any direction. The compact device enables the operator to support the patient easily during measurement, even if the patient's eyelid needs to be lifted. These unique aspects will contribute to space saving and a flexible layout in your eye examination room.



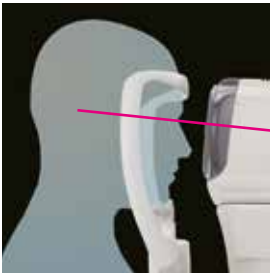

KR-1

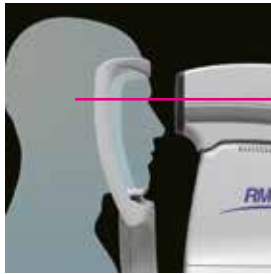

Conventional model

**Compact Ergonomic Design**

The KR-1's ergonomic design provides a more comfortable position for the patient with an inclined optical head (5°). The compact instrument enables easier access for patients.

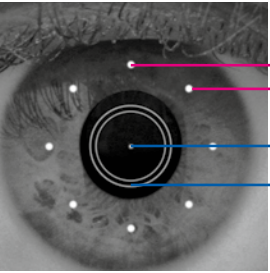

Peripheral Points  
Corneal Apex  
KRT Ring

**Peripheral KRT**

The KR-1 allows the operator to capture 8 peripheral corneal curvature measurements in addition to the central data.

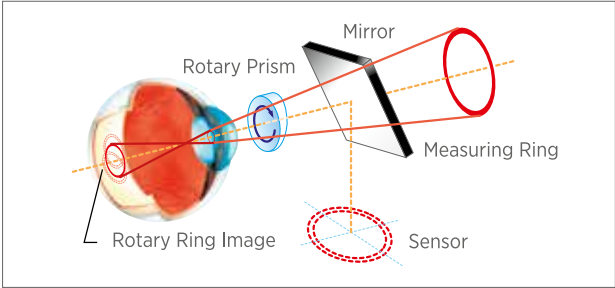

**Topcon's Rotary Prism Measuring System**

With Topcon's Rotary Prism Technology, the KR-1 provides stable measurement. The unique, eccentric rotation of the measurement ring, is designed to reduce the artifact from the fundus.

**Easy-to-Use Color Touchscreen Control Panel**

ID	Cataract	Settings
Right Eye	Fixation Target	Left Eye
Chinrest Up/Down	FOG	Move device forward and backward
Position Reset	Target Image	Start*
Measuring Mode	Print	Auto/ Manual
	Corneal Diameter	
	All Clear	

\*Pressing the 'Start' button results in immediate data capture, which may be necessary for less cooperative patients, or patients with significant corneal disease, that can make auto-alignment and focusing difficult.

# KR-800S

- Objective & subjective measurement
- VA charts from 0.1 to 1.2
- Reading power assessment on various distances
- Comparison of subjective, eyeglass & unaided VA's
- Pre- & post-cataract surgery VA assessment



The KR-800S is unique because it features not only objective auto refraction and keratometry, but it also performs subjective far and near testing as well as four function tests. These 6-in-1 functions assure quick and accurate results and enhance your test workflow.

The test results of all objective and subjective measurements are shown on the monitor and can easily be printed through the drop-in printer in front of the instrument. It is very easy to test objective measured results subjectively. The accurate objective results can be spherical edited until the highest visual acuity (VA) is achieved. Additional reading power can be measured on various distances between 33 cm and 60 cm.

If a computerized lens meter is connected, the instrument can also test and show the patient's VA result with their current eyeglasses. Since it is easy to compare VA with the patient's current eyeglasses result or even with unaided situation, new eye glasses can be advised if necessary.

The glare, grid and contrast test availability in combination with VA measurement make the KR-800S a versatile instrument that is an asset not only for opticians but also for ophthalmologists with pre-cataract, post-cataract or refractive surgery.

KR-800S can provide pre- & post-cataract surgery visual acuity information in order to review the cataract surgery outcome. The KR-800S is able to simulate the use of premium IOL's such as Toric IOL or Multifocal IOL's. The patient can experience the influence of premium IOL's on their visual acuity. This makes the KR-800S a perfect instrument in addition to Topcon's biometer ALADDIN.





- 3D Auto Alignment function allows quicker & easier measurement
- Smooth operation
- 8.5 inch touchscreen control panel
- Compact designed body
- Easy set-up with a LAN network

Topcon has significant experience in designing and producing high quality kerato refractometers and tonometers. For a greater customer experience, Topcon has developed the semi auto kerato-refractometer KR-800A with 3D auto alignment function. KR-800A offers enhanced efficiency and easier operation to improve day to day examination of the workflow in a practice.

### 3D auto alignment function maintains proper alignment with the patient

3D auto alignment feature maintains XYZ alignment even during small eye movements, providing consistent and repeatable measurements.\* The operator follows the alignment guidance on the monitor for initial alignment, following by the start of automatic alignment and measurement. 3D auto alignment function supports easy operation.

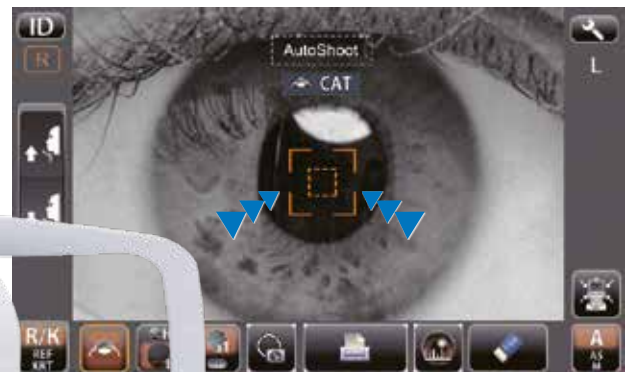

\*Manual alignment may be required for patients with poor fixation.

- Topcon's Rotary Prism Technology™ for unparalleled accuracy
- User friendly
- Compact & modern design
- 8.5 inch LCD touchscreen panel
- Connectable LAN

The KR-800 & RM-800 auto kerato- and refractometers incorporate the very latest in design technology and ergonomics. The units feature a bright 8.5 inch color touchscreen panel to control the main functions and an improved joystick operation due to a 23% reduction in weight from the previous models. Topcon systems have been renowned for their accuracy due to the proven Rotary Prism Technology™.

The compact footprint and design of the KR-800 and the RM-800 will save space and add functionality to the contemporary eye care practice.

The LAN connectivity for data export and the drop-in printer in front of the instrument ensure versatile use of the KR-800 and RM-800.

### Rotary prism measuring system

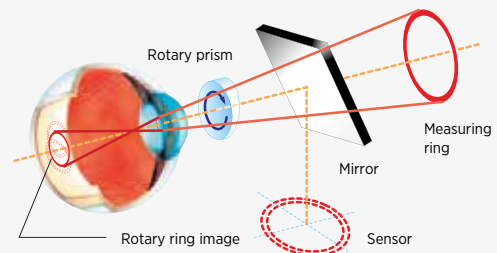

# Lens Meters

# SOLOS

SOLOS enables advanced, accurate lens analysis with the touch of a button

SOLOS is a fully automated lensmeter with a full range spectrometer that detects, measures and marks single vision, progressive and other multifocal lenses glazed in a spectacle frame or as uncut lenses.

## Features



Automated, One-Touch Operation



Lens Mapping



UV-A, Blue Light and Visible Light Transmittance Measurements



Automatic Marking



Automatic Lens Type Detection



Wireless Data Transfer



Extended Measurement Range (Up to +/- 20D)



## Connectivity

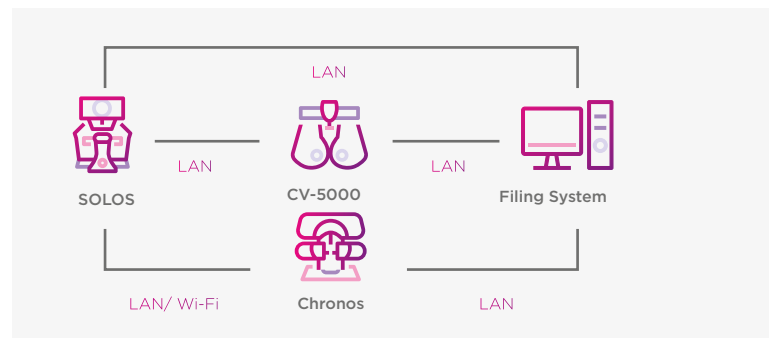



### Simple Workflow

SOLOS combines a mapping-type lensmeter with a full-range spectrometer and lens marking for advanced lens analysis.

With a single touch, SOLOS automatically positions each lens, detects the lens type and performs comprehensive measurements of both lenses within a spectacle frame.

The spectral transmittance meter is designed to measure light wavelength transmission in all types of lens material. The transmittance graph helps explain the benefits of UV-A and blue light protection to the eyeglass purchaser.

Measurement results can be sent to the built-in printer and can be exported to an EMR, Topcon's CV-5000S digital phoropter or Chronos binocular refraction system.

## Comprehensive Measurements



Progressive Lens



Sphere, Cylinder, Axis, Add and Pupil Distance



Prisms - Cartesian Coordinates

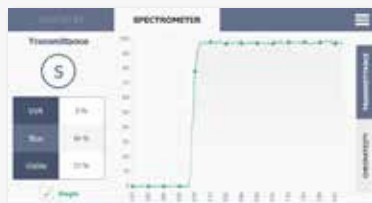

UV-A, Blue and Visible Light Transmittance Percentages

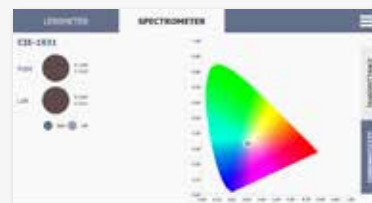

Lens Tint - CIE Chromaticity

# CL-300

- LCD color touch panel
- Compact slim body
- Automatic mono- & multi-focal detection
- UV transmittance measurement
- Green measurement light beam

The Topcon CL-300 is a computerized lens meter with a touchscreen panel and UV meter.

The compact, ergonomic design of the Topcon CL-300 and intuitive colored touchscreen ensure that measurements can be easily and quickly obtained.

The CL-300 automatically detects and measures all types of lenses, including progressive lenses. Contact lenses can easily and comfortably be measured with the Topcon CL-300 as well. Due to the green light reading beam, ABBE compensation is no longer required.

The UV measurement function provides information on the ultraviolet transmittance in the range of 0% to 100%, providing reliable measurement results for eyeglasses and sunglasses.



	CL-300 PL	CL-300 DPL
PD measurement	●	●
Printer	●	●
LAN connection	●	●
Standard marking	Ink cartridge with white ink	Steel needles with red ink

The Topcon LM-8 makes measuring lenses with a low range cylindrical power very easy. The combination of high magnification optics and the excellent wide field eyepiece make this possible.

The LM-8 is battery operated. The LM-8 lens meter has an improved optical system and a LED illuminated target for glare-free viewing and fatigue free operation.

The instrument also features a cartridge type marking device and a redesigned eyepiece.

- LED illumination target
- Battery operated
- Built-in prism compensator



## Slit Lamp LED type



### **SL-2G**

LED Slit Lamp



### **SL-D4 LED**

Digital Slit Lamp



### **SL-D701**

Digital Slit Lamp

## Slit Lamp halogen type



### **SL-D2**

Digital Slit Lamp



### **SL-D301**

Digital Slit Lamp



### **SL-D4**

Digital Slit Lamp



# Slit Lamps and Imaging Solutions

SL-2G | SL-D4 LED | SL-D701 | SL-D2 | SL-D301 | SL-D4 | DC-4 | BG-5

# SL-2G

- LED illumination: prolonged life time
- Three magnifications: 10x, 16x, 25x for daily general practice
- Blue & red-free filter: improve diagnosis
- Various accessories, such as tonometer and yellow filter: improves workflow
- Short construction: user-friendly ergonomics (short ocular distance to patient)

The SL-2G has excellent clear optics and an ergonomic construction. The optics are of the Galilean type. This model can be equipped with accessories such as Topcon Fundus Viewer FV-1L and the Goldmann tonometer.

The Topcon SL-2G Slit Lamp is a basic Slit Lamp in Topcon's product range. The SL-2G has a LED light source which is economical and environmentally friendly. The SL-2G is the most economical model in the Topcon Slit Lamp range. It provides renowned Topcon quality and sufficient flexibility to cover the basic needs of the general practice.

The LED light has an approximate life time of 10,000 hours which is 100 times longer than conventional halogen bulbs. The LED light source offers a uniform and consistent illumination. The SL-2G Slit Lamp incorporates 10x, 16x and 25x magnifications, furthermore it incorporates blue and red-free filters.

Goldmann tonometers, a yellow filter, the Topcon parallel binocular tube and the Topcon Fundus Viewer are optional.



- Clear and homogeneous LED illumination
- Five magnifications by rotating drum (6X, 10X, 16X, 25X, and 40X)
- Blue-Free Filter™ System for 1.6x brighter fluorescein observation<sup>1</sup>
- Topcon's optical quality
- Amber filter for observation of vessels
- Compact and easy to use

<sup>1</sup>The Blue-Free Filter™ System is the combination of the optional accessory Yellow Filter Unit, and the Blue Filter which is a standard component of the SL-D4 (Type: LED)

The SL-D4 LED is the latest addition to Topcon's D-Series Digital Slit Lamps.

It can be used as a conventional examination instrument or with the optional DC-4 integrated digital camera for high resolution imaging.

This Slit Lamp features LED illumination, excellent optics and five convenient magnification ratios, allowing it to be used across a wide variety of ophthalmic applications.

### Topcon Blue-Free Filter™ System<sup>1</sup>

Observation can be performed using the Blue-Free Filter™ System, by using the incorporated exciter filter with the optional barrier filter<sup>2</sup>. Tear dynamics and subtle ocular surface damage can be more clearly viewed, with greater contrast and fewer artefacts.<sup>4</sup>

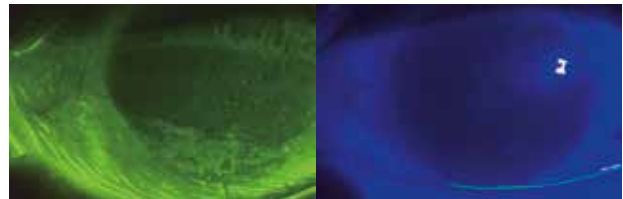

Blue-Free Filter<sup>3</sup>

Cobalt Blue Filter<sup>3</sup>



<sup>1</sup> Optional accessory

<sup>2</sup> Shizuka Koh et al., "Diagnosing Dry Eye Using a Blue-free Barrier Filter", American journal of ophthalmology, 2013 September

<sup>3</sup> Images provided by Toru Noda, M.D, Department of Ophthalmology, Tokyo Medical Center

<sup>4</sup> Arita R, Morishige N, Fujiii T, et al., "Tear Interferometric Patterns Reflect Clinical Tear Dynamics in Dry Eye Patients", Investigative Ophthalmology and Visual Science, July 2016

- Five magnifications:  
6x, 10x, 16x, 25x & 40x for daily specialist use
- Halogen & LED illumination source available
- Four filters for enhanced examination
- Blue-Free Filter™ System for 1.6x brighter fluorescein observation
- Oblique illumination prevents reflection
- Optimal clarity, color resolution & depth-of-field

The SL-D701 is a digital Slit Lamp which can be used with conventional halogen illumination or with LED illumination. The LED illumination allows observation under a brighter, homogeneous condition than the conventional halogen illumination. LED illumination ensures consistent color temperature during light intensity adjustment. Due to a shorter LED wavelength easier visualization of details in the anterior chamber and vitreous such as flare and inflammation is obtained.

The SL-D701 incorporates four filters which can be selected; a cobalt filter, red-free filter, neutral density filter and an amber filter. The amber filter improves the contrast and color of retinal observation. The SL-D701 has 12.5x eyepieces and converging binocular tubes with a parallel magnification body (6x, 10x, 16x, 25x and 40x) for extremely sharp stereoscopic observation. As standalone the joystick trigger button of the SL-D701 provides an illumination boost for detailed observation, available for halogen illumination and LED illumination.

### Topcon Blue-Free Filter™ System<sup>1</sup>

Observation can be performed using the Blue-Free Filter™ System, by using the incorporated exciter filter with the optional barrier filter<sup>2</sup>. Tear dynamics and subtle ocular surface damage can be more clearly viewed, with greater contrast and fewer artefacts.<sup>4</sup>

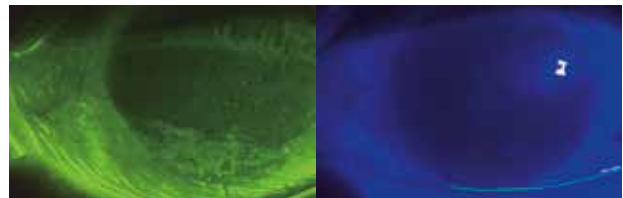

Blue-Free Filter<sup>2</sup>

Cobalt Blue Filter<sup>3</sup>

### Digital applications

The SL-D701 Slit Lamp incorporates a cable management system, if used as a digital Slit Lamp. The SL-D701 will seamlessly integrate with:

- DC-4, a 5 megapixel camera
- BG-5, background illumination / meibography system
- Topcon Fundus Viewer FV-1L

### Options

The SL-D701 has options such as a yellow filter diaphragm filter to increase depth-of-field, tonometer mount, parallel binocular tubes, assistant observation tube and various relay lenses.

<sup>1</sup> Optional accessory  
<sup>2</sup> Shizuka Koh et al., "Diagnosing Dry Eye Using a Blue-free Barrier Filter", American journal of ophthalmology, 2013 September

<sup>3</sup> Images provided by Toru Noda, M.D, Department of Ophthalmology, Tokyo Medical Center  
<sup>4</sup> Arita R, Morishige N, Fujii T, et al., "Tear Interferometric Patterns Reflect Clinical Tear Dynamics in Dry Eye Patients", Investigative Ophthalmology and Visual Science, July 2016



The SL-D2 digital Slit Lamp has the same product features and options as the SL-D4, except for the magnification. The SL-D2 has two less magnifications.

The SL-D2 has standard 12.5x eye pieces and converging binocular tubes with a parallel magnification body with 10x, 16x, and 25x magnification for remarkably sharp and comfortable stereoscopic observation.

### Digital applications

The SL-D2 Slit Lamp has a cable management system, if used as a digital Slit Lamp.

- SL-D2: three magnifications: 10x, 16x, 25x for daily general practice
- Optimal clarity, color resolution & depth-of-field: easy diagnosis
- Compact & user-friendly



# SL-D301



The Topcon SL-D301 is a classic and economical Slit Lamp especially designed with the optometry clinic in mind. The SL-D301 is a stereoscopic converging biomicroscope with excellent optics of the Galilean type, which produces a sharp and clear view. The halogen illumination and 9 mm field of view in combination with 3 magnification selections (10x, 16x & 25x) assist you in a wide range of screening applications.

The SL-D301 is compatible with the optional Topcon DC-4 digital camera which offers high resolution still imaging, video capabilities with auto exposure and smart capture function.

- Three magnifications; 10x, 16x & 25x
- Blue filter, red-free filter, ND filter, UV cut filter & IR cut filter
- Halogen illumination
- Topcon DC-4 digital camera compatible



The SL-D4 is part of Topcon's digital Slit Lamp series. This digital Slit Lamp can be used as a conventional biomicroscope or as a Slit Lamp with several imaging options.

The SL-D4 incorporates three filters: a blue, red-free and an amber filter. The amber filter improves the contrast and color of retinal images.

### Digital applications

The digital camera DC-4 seamlessly integrates with the SL-D4 Slit Lamp.

The SL-D4 digital Slit Lamp has many options such as a yellow filter and background illumination.

- SL-D4: five magnifications: 6x, 10x, 16x, 25x, 40x ideal for viewing details, for daily specialist practice
- Optional DC-4 digital camera: a modular system
- Small footprint: compact & space saving unit providing ease of use
- Short construction: user-friendly ergonomics (short ocular distance to patient)
- All cables are integrated in the Slit Lamp arm: aesthetic





- Smart Capture Function:  
five images captured in rapid succession
- Live View:  
see exactly what you are capturing on screen
- Still Image with Auto Exposure (AE) Function:  
always the correct color and brightness balance
- Video Capability:  
video clips are easily obtained and displayed
- Meibomian Gland Status:  
view and document Meibomian glands condition with infrared viewing

The DC-4 is a digital camera for capturing still images or videos for detailed analysis and diagnosis. The DC-4 has a five megapixel CMOS chipset for a crisp capture similar to the binocular observation quality. The DC-4 is very user friendly, images and videos are made by pushing the joystick of the Slit Lamp. Incorporated is an infrared cut filter for sensitivity of infrared illumination of BG-5, capturing and making meibomian glands clearly visible.

### Smart capture function

The DC-4 digital camera has a smart capture function. It is possible to rapidly obtain a series of five images of which the best picture can be selected. The smart capture function minimizes failed images or blurry pictures, especially with children and in conditions of excessive blinking.

### Auto exposure function

By adjusting the shutter speed and sensor gain, the brightness of the image will be automatically compensated. As a result the binocular observation and the final picture will have the same color balance.

The Topcon DC-4 also comes with the basic IMAGEnet<sup>®</sup> software and is compatible with the Topcon SL-D Series Slit Lamps.

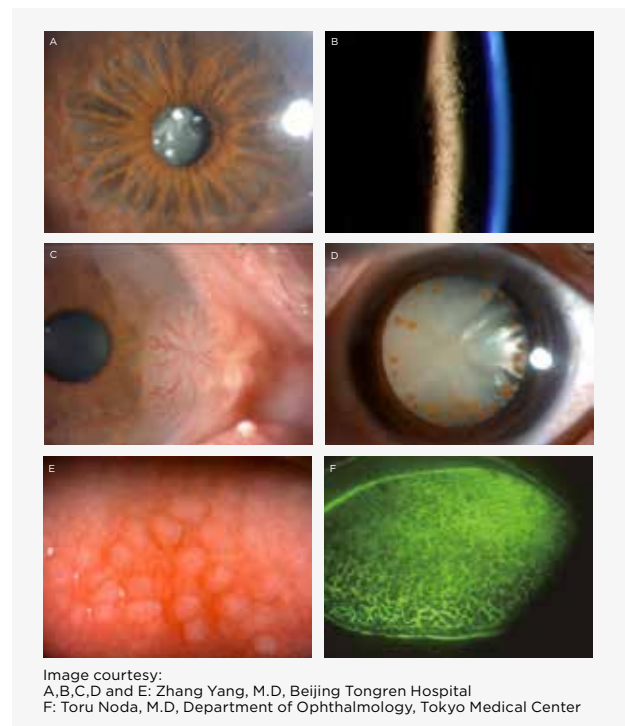



- Provide infrared illumination which enables observation of meibomian glands
- Adapts to Topcon Slit Lamp SL-D701
- Provides shadow free observation



The Topcon BG-5 background illumination consists of a white LED source. The background illumination is required to use to overview images with low magnification and will provide a shadow free observation with natural colors. For the background illumination two apertures are available which result in a high and low brightness.

The BG-5 also provides infrared illumination that illuminates the Meibomian glands to assess its integrity. The observed images can be displayed on a computer screen and captured with the Topcon digital Slit Lamp camera, DC-4. The BG-5 can be mounted on Topcon Slit Lamp model SL-D701 exclusively.

## Meibomian Gland Observation

The Meibomian glands can be examined and their status documented using the optional BG-5 illumination system in selected models.<sup>1,2</sup>



Grade 0



Grade 1



Grade 2



Grade 3

Courtesy for the Meibomian gland images: Reiko Arita, MD, PhD, Itoh Clinic, Department Ophthalmology, University of Tokyo School of Medicine.

<sup>1</sup> The selected configuration is Digital Slit Lamp SL-D701 + Digital Camera DC-4 + background illuminator BG-5.

<sup>2</sup> Arita Reiko et., "Development of Definitive and Reliable Grading Scales for Meibomian Gland Dysfunction", American journal of ophthalmology September 2016 ;169:125-137

---

Optimize workflow and  
grow your practice  
with guided binocular  
refraction.



# Refraction

## It is time to reinvent refraction.



Chronos offers binocular autorefractometry, keratometry measurements and visual acuity with subjective testing. Chronos is a single space-saving instrument that optimizes your workflow.



### DELEGATE

SightPilot™ is a guided refraction system that simplifies the exam and facilitates delegation.



### GROW

Chronos offers the versatility critical for growing your practice.



### SAVE SPACE

Chronos combines binocular autorefractometry and keratometry measurements with binocular subjective testing and visual acuity in a single instrument that occupies minimum space.

Chronos reduces the number of conventional refraction lanes and additional refractometers needed.



### SAVE TIME

Chronos saves time by optimizing workflow, eliminating the time taken to clean and move between devices.

**Chronos offers RTC**  
(Remote Tablet Control) for  
social distance protocol.\*

\* Applicable distance is subject to the device's communication performance and the communication environment.

- SightPilot™ simplifies the user interface to provide a step-by-step guide through the refraction process.
- At each step, the operator is given instructions to proceed with the refraction, based on the patient's response.

SightPilot™ is optimized for understanding and efficient workflow, facilitating delegation when required.



# Product description

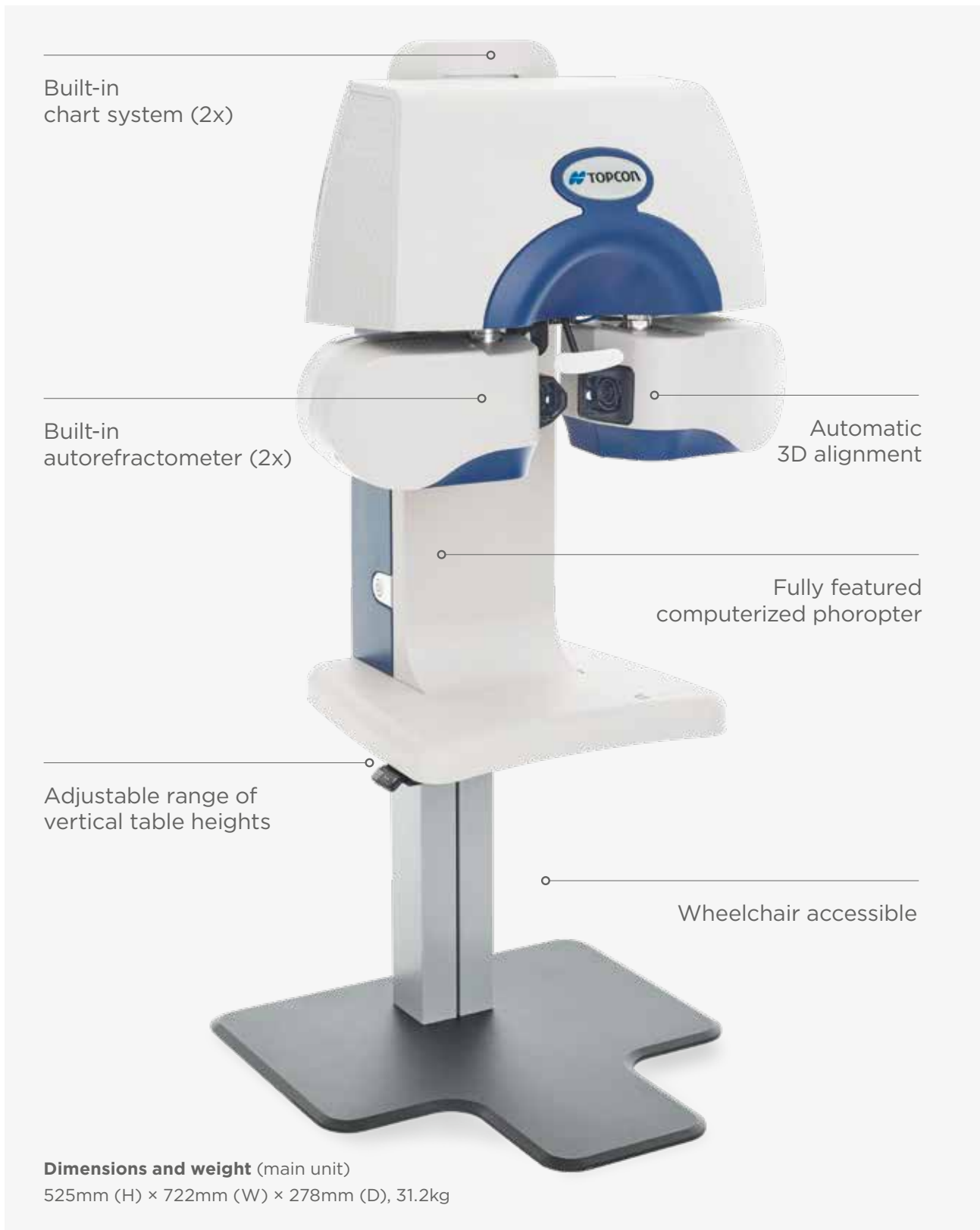

# Vision Testers

# CV-5000PRO Phoropter

Topcon's CV-5000PRO automatic phoropter sets quality standards. Fast lens rotation provides comfort for user and patient. The compact and contemporary design enhances the professional image of the practitioner. Due to the compact design the refractionist can monitor the patient's expression during refraction. To perform the near tests, the near chart illumination is incorporated into the CV-5000PRO.

The CV-5000PRO automated phoropter can be controlled by a tablet, by the Topcon KB-50S controller or by PC software operation.

- Compact design
- Fast lens rotation
- Versatile operation
- Near chart LED illumination





We offer different options to control the CV-5000PRO automated phoropter and the CC-100 digital visual acuity chart.

- The KB-50S, an ergonomic control panel with large built-in touch screen, is a very user friendly solution for smooth operation of the setup.
- A monitor and mouse can be connected to the system and offers easy operation by only mouse control.
- If you prefer to work wirelessly, you can also connect a tablet and operate the system remotely.
- It is possible to use your tablet in different exam lanes. With a special version of the system it is also possible to control the setup from a desktop PC.



PC Software



KB-50S



CV-5000 Tablet

The VT-10 vision tester is a basic phoropter in the Topcon product range. The VT-10 is a reliable no-nonsense vision tester which has a wide array of lenses in order to perform all the refractive tests you need.

### Synchronized cross cylinders

The VT-10 is equipped with a cross cylinder that automatically rotates in conjunction with the set cylinder axis. Special gearing automatically synchronizes the rotation of the loop each time the cylinder axis correction is changed.

### Easy convergence system

A convergence system allows natural conditions for near testing. Multicoated lenses for superior optical performance. The coating eliminates flare, ghost images and reflections. The multicoated lenses assure clearer, brighter images with improved contrast.

- Wide testing range
- Synchronized cross cylinders
- Convergence system
- Multicoated lenses
- Easy to operate



# Chart Systems

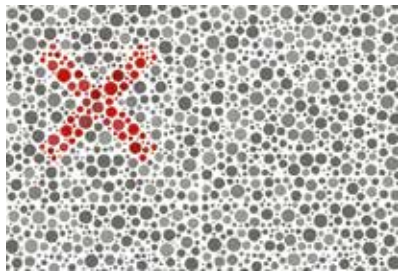

The Topcon LED LCD chart system contains all important visual acuity, binocular, color vision and contrast sensitivity tests. The most remarkable feature is the Topcon patented circular polarisation.

### Spatial frequency contrast sensitivity test

A unique feature is the availability of the spatial frequency contrast sensitivity test which provides quantitative and qualitative information about the patient's contrast visual acuity.

### Circular polarisation

Image separation for binocular testing is created through a specific polarisation technique which is unique to LCD test charts. This unique polarisation technique provides 100% image separation, without any "ghost images". Circular polarisation provides equal background color for both eyes.

The CC-100XP is a 22 inch LCD screen with high resolution, high contrast and high brightness. CC-100XP can be operated by the Topcon CV-5000 automated phoropter, by a remote controller, or by a wireless CV-5000 Tablet solution.



- 22 inch LCD screen
- 100% polarisation
- Wide range of optotypes
- Virtually unlimited test charts
- Spatial Frequency contrast sensitivity test
- White Maddox LED light source
- MKH test sequence according to Haase
- WiFi & USB connection
- CV-5000 Tablet ready

The CC-100 is a versatile solution to present charts to patients. The high resolution 22 inch LCD monitor ensures a clear and bright chart display.

The CC-100 provides image separation through red and green images. All common known visual acuity tests are available including ETDRS. The design of the CC-100 fits seamlessly to other Topcon refraction products.

Both the CC-100 and CC-100XP can be operated by Topcon's CV-5000 CV system using a PC, the KB-50 one-dial controller or a wireless tablet. It is also possible to operate the CC-100 by a remote controller.

- 22 inch LCD screen
- Wide range of optotypes
- Virtually unlimited test charts
- White Maddox LED light source
- MKH test sequence according to Haase
- WiFi & USB connection
- CV-5000 Tablet ready



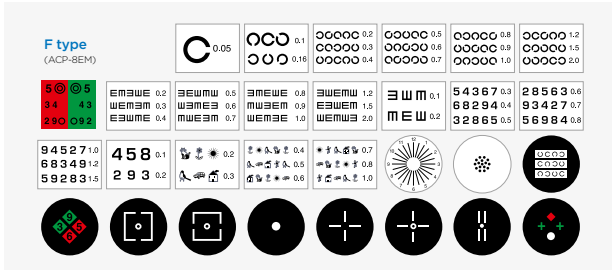
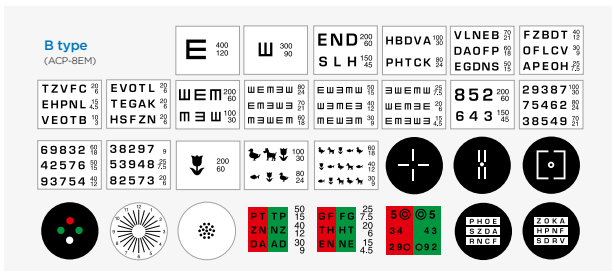
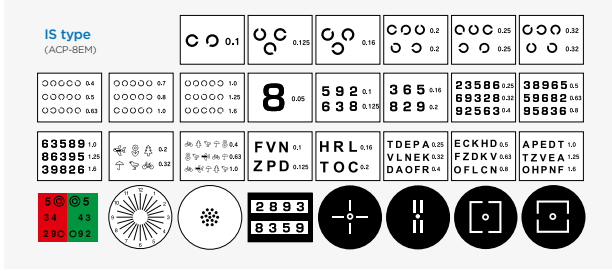
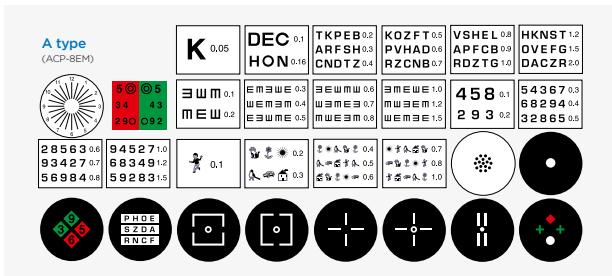

The Topcon ACP-8EM chart projectors provide sharp images and image projections with a fast chart disc rotation. The remote controller allows a fast and simple chart projection of 30 test charts at a rate of 0.03 seconds per chart frame. The enlarged projection size of 330 x 270 leaves a clear and wide view. This chart projector shows five optotypes per line and the possibility to mask visual acuity lines or show a single optotype.

- Easy operation
- Connection with CV-5000 system
- 30 built-in charts
- Masking of optotypes



# Wavefront Analyzer

- 5 functions in 1 (wavefront aberrometry, corneal topography, refractometry, keratometry & pupillometry)
- Unsurpassed reproducibility & reliability
- Automated r/l measurement & touch panel manipulation
- Decision support for cataract & refractive procedures
- Increased patient throughput through efficient workflow
- Wavefront image sequence
- Simulated visual acuity (VA) assessment
- Full auto alignment
- Easy operation & handling
- Integrated evaluation software

The Topcon KR-1W is the only wavefront & topography system to offer both refractive and diagnostic functionalities. The instrument can be used for wavefront aberration, corneal topography, pupillometry, keratometry and auto-refraction. All measurements are performed by one push on the joystick.

The Topcon KR-1W will help speed up your workflow, improve communication with patients and monitor the outcomes of your treatments.

The KR-1W wavefront & topography system has an auto alignment system, for increased ease of use and user-friendly operation.

This 5 in 1 unit provides you with the ideal tool to diagnose, follow up and make treatment plans for a broad range of ocular conditions, resulting in increased efficiency in your practice and patient satisfaction.





# Specular Microscope

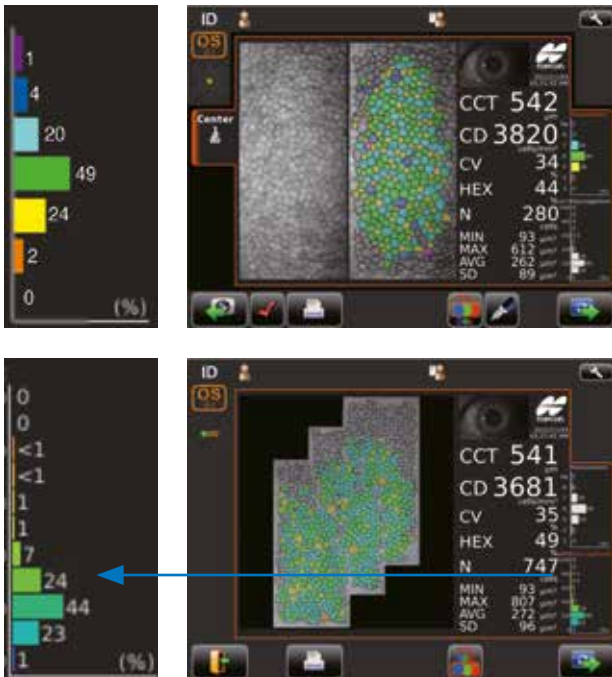

The Topcon specular microscope SP-1P has a modern ergonomic design and innovative features that simplify its use and increase its efficiency.

A large 10.4 inch rotatable touch panel monitor eliminates the need for a control lever and can be turned to various angles for better interaction with the patient. By simply tapping on the centre of the patient's pupil displayed on the monitor the SP-1P automatically centres, focuses, acquires and analyzes the endothelial cell image.

The entire operation takes a few seconds, it is fast, smooth and requires minimum training. The space saving features combined with its ease of use makes the SP-1P the instrument for a new generation in eye care.

- Wide Angle “panorama” photography mode - substantial size increase of the analyzed area
- Two specific photography modes - sequence course & free style course
- Quick automatic measurement & analysis - instant acquisition of the analysis result & intuitive operation
- Easy-to-read screen & comprehensive analysis software - frequently referred values are shown on top & a pleomorphic / polymegathic histograms can be shown with color



# Operation Microscopes

# OMS-800 Series



## Components

	OMS-800 OFFISS	OMS-800 OFFISS CBS	OMS-800 Pro	OMS-800 Pro CBS	OMS-800 Standard	OMS-800 Standard CBS
<b>OFFISS</b>	○	○	-	-	-	-
<b>Electromagnetic locking</b>	○	○	○	○	-	-
<b>Coarse focusing</b>	○	○	○	○	-	-
<b>Inverter</b>	○	○	-	-	-	-
<b>Achromatic optics</b>	○	○	○	○	○	○
<b>Beam splitter</b>	○	-	○	-	○	-
<b>Changeable beam splitter</b>	-	○	-	○	-	○
<b>Illumination angle</b>	Full Illumination ( $\pm 2^\circ, +4^\circ$ ) / $\pm 2^\circ$ / Yellow Filter ( $+4^\circ$ )					

## OMS-800 OFFISS

OFFISS offers an enhanced scope of possibilities in vitreoretinal surgery. Equipped with the OFFISS lenses mechanism, electromagnetic brakes and sophisticated electronics, this model provides the highest specification for intravitreal surgery, as well as other ophthalmic procedures.

## OMS-800 OFFISS CBS

The CBS model offers a changeable beam splitter control using a lever, allowing the beam to be split 80/20 or 50/50. When connected to a TV camera, the 50/50 mode allows clearer TV images for documentation or teaching purposes.

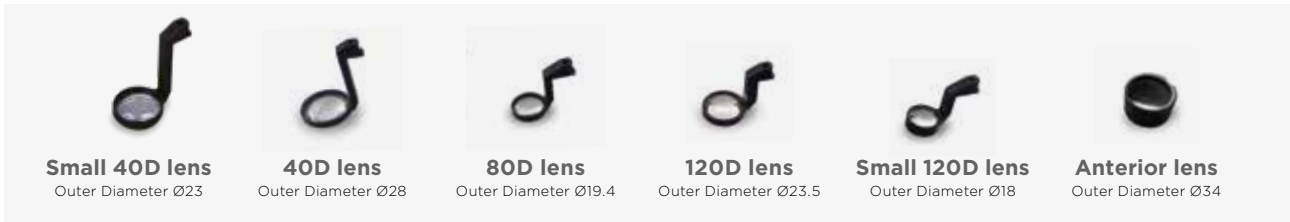

## OFFISS Lenses (OFFISS: Optical Fiber Free Intravitreal Surgery System)

Topcon has developed a state-of-the-art observation system for vitrectomy procedures that does not require the use of fiberoptic illumination. The Topcon OFFISS lenses avoid complicated focusing by allowing the microscope head and indirect lens to move independently of each other, facilitating a clear focused image at all times. The image inverter activates automatically whenever the OFFISS is in use. The indirect lens can quickly and simply be exchanged for another, saving time and increasing efficiency.

### OMS-800 PRO

Electromagnetic brakes and sophisticated electronics provide the OMS-800 PRO with the flexibility to facilitate virtually any type of ophthalmic surgical procedure.

### OMS-800 Standard

Equipped with most of the features of the OMS-800 range, the OMS-800 Standard answers the need for a simpler, easy to use operation microscope. Manual brakes and ease of mobility make the OMS-800 an affordable yet advanced unit for all ophthalmic procedures.

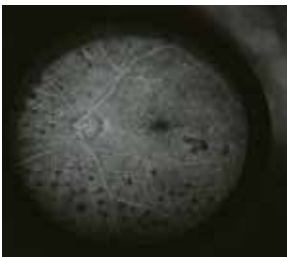

### Intraoperative fluorescein observation

With this attachment, the surgeon can perform fluorescein angiography during the surgery, allowing real-time assessment of the retinal condition. Available with OMS-800 OFFISS only.

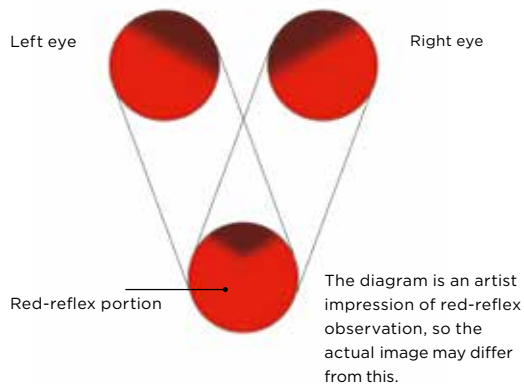

## Coaxial illumination

The designed illumination system of the OMS-90 assures the finest optical performance. The optical system has been fitted with an innovative design that allows the surgeon to view a sharper image with more clarity than ever before.

The illumination system of the OMS-90 produces a superior red-reflex image for assistance in surgical procedures. As shown in the diagram, the innovative system design merges two improved fields of views to produce an enhanced red-reflex and an unparalleled image quality.

- Coaxial illumination
- Stain-proof coated objective lens
- Parallel binocular tube
- PD Adjustment Knob
- Built-in yellow filter
- Compact base





### Built in yellow filter

The flip in/out yellow filter is built into the system to allow full protection against retina phototoxicity.

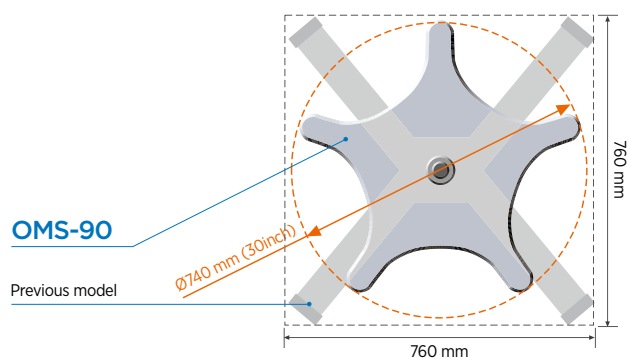

### Compact base

The sturdy and compact  $\varnothing 740$  mm (30 inch) base is designed for optimal use of limited operating room floor space.



# Industry-Leading Pattern Scanning Laser Technology

Pascal® Synthesis™



Pascal

Conventional Laser

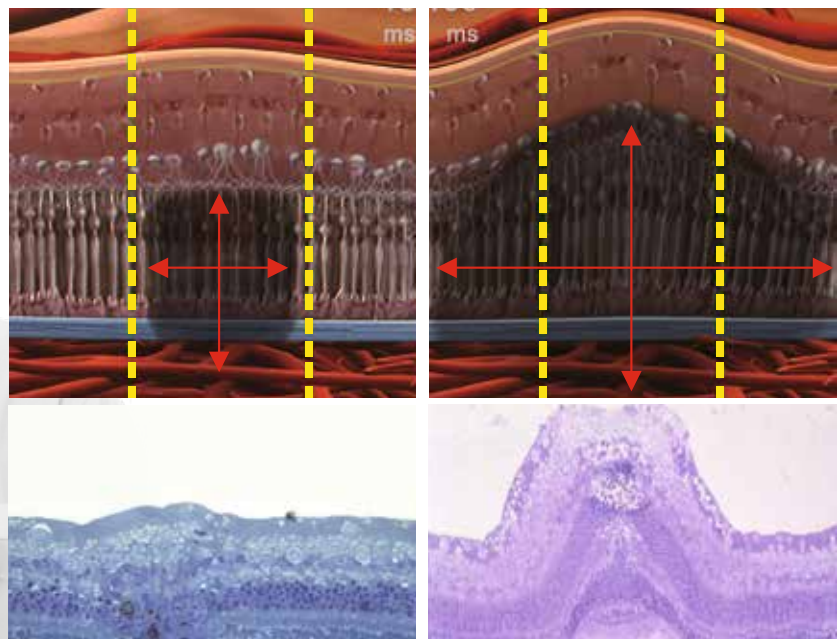

**Courtesy:** Dr. Daniel Palanker Associate Professor Department of Ophthalmology, School of Medicine, and Hansen Experimental Physics Laboratory Stanford University.



# Pattern Scanning Laser

# Pascal<sup>®</sup> Synthesis<sup>™</sup> Pattern Scanning Laser

- Exclusive Precision Spots with Multi-Fiber Beam Technology
- Reduced power and short pulses produce less discomfort during treatment
- Rapid pattern scanning laser delivery
- Precise alignment and continuous laser pulse directed by high speed galvanometers
- Enhanced laser delivery slit lamp
- Endpoint Management<sup>™</sup> for sub-threshold treatment<sup>1</sup>
- Pattern Scanning Laser Trabeculoplasty (PSLT)<sup>1</sup> for IOP reduction<sup>2</sup>

With enhanced optics, improved ergonomics, intuitive software, and subthreshold capabilities, the Pascal Synthesis allows faster procedures with less pain, collateral damage and scarring for your patients.<sup>3</sup>

Pascal represents a quantum leap in ophthalmic treatment technology and is committed to helping you deliver effective results for your patients. Demanding ophthalmologists choose Pascal because of its speed and ease of use.

Developed in partnership with Stanford University, the Pascal method of photocoagulation treats retinal conditions using a single spot or a user-selected pattern array. Most importantly, it was designed to provide control and flexibility in the treatment of eye conditions.



1. Optional  
2. Mauricio Turati, Felix Gil-Carrasco, Adolfo Morales, Hugo Quiroz-Mercado, Dan Anderson, George Marcellino, Georg Schuele, Daniel Palanker. "Patterned Laser Trabeculoplasty." *Ophthalmic Surg Lasers Imaging* 2010;41: 538-545.  
3. Manish Nagpal et. al., "Comparison of laser photocoagulation for diabetic retinopathy using 532-nm standard laser versus multispot pattern scan laser." *RETINA* 30:452-458,2010

## A New Laser Delivery Slit Lamp SL-PA04



### Ergonomic Design and Improved Optical Design

Improved coaxiality between the slit illumination and the aiming beam provides better visibility of the peripheral retina.

### Comfortable Observation with our NEW Binocular System

The CB-8 binocular system with 8-degree angle provides clear vision. The smooth movement of the PD adjustment makes it easier to find a comfortable PD range. New magnification configuration improves visibility of the treatment area. The 5x, 8x, 13x, 20x and 32x magnification grouping allows for a wider view of the treatment area.

### Power Adjustment Knob

Quick and precise adjustment of the laser treatment power.

### LED Illumination

Sharp and homogeneous LED illumination for comfortable viewing.

### Gooseneck Fixation Target

Easy to adjust the fixation target.

### Micro-manipulator

Allows precise alignment of aiming beam and treatment delivery.

## Multi-Fiber Beam Delivery System

Pascal® Synthesis™ multi-fiber beam delivery provides one dedicated fiber optic for each

spot size. This increases depth of field compared to zoom optic laser systems.

### Multi-Fiber Beam Delivery

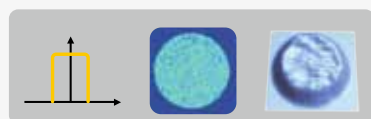

Profile image of beam delivery:  
Pascal has uniform energy distribution

### Zoom Optic Laser Systems



Profile image of beam delivery:  
Other lasers have "hot spots" in the beam profile

# Endpoint Management<sup>™</sup> Sub-threshold Treatment for Retinal Disorders

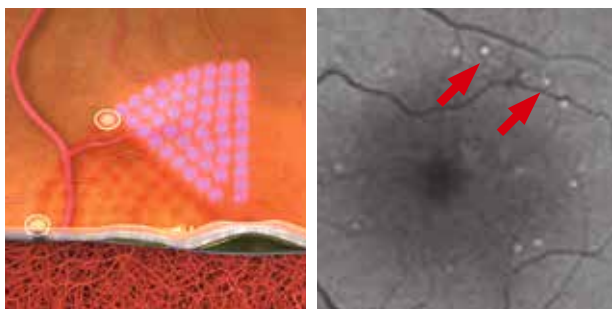
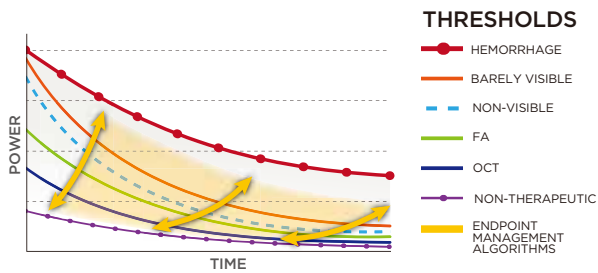

EpM OFF

EpM ON /  
Landmark OFF

EpM ON /  
Landmark ON

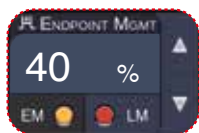

## With Endpoint Management<sup>™</sup>

Endpoint Management (EpM)<sup>\*</sup> is a pattern sub-threshold retinal laser therapy that uses a unique algorithm to control laser power and pulse duration, optimizing the therapeutic effect of the laser at sub-visible levels.

## Mathematically Precise

The Arrhenius Integral coupled with extensive data on retinal laser-tissue interactions defines the algorithms for Endpoint Management. By use of this formula, heat induced changes in the retina are controlled as Endpoint Management simultaneously modulates the laser power and duration, providing linear control over a non-linear process.

## Landmark<sup>™</sup> Patterns

The Landmark feature is a useful tool for tracking the sub-visible areas which have been treated, assisting with the treatment process and taking the guesswork out of successive treatments.

## Easy Operation

The yellow dots displayed on the user interface treatment pattern display indicate the laser spots that will be delivered using the energy level set by Endpoint Management. While End-point Management is active, the red dots indicate the laser spots that will be delivered at the titration energy level ("100% level") and will provide the "Landmark" reference points outlining the treated area.

<sup>\*</sup>EpM is optional software

# Instrument Tables

Whether it is a digital Slit Lamp with digital camera, an OCT or a non-mydratic fundus camera, this workstation offers a compact, clean and clear working environment. Monitors, PC and cables will be neatly installed, due to a unique cable management system.

The ATE-800 table is wheelchair friendly and has a unique elevation stroke which is very comfortable for patients.

The basic table can be upgraded with several accessories such as a PC holder, a tray for a printer or a key board tray.

- Versatile desktop design
- Unique stroke of 350 mm (minimum 628 mm & maximum 978 mm)
- Storage for PC, keyboard & printer
- Unique cable management system
- Robust rubber shielded wheels
- Patient friendly design



# ATE-700(PC), ATE-600, ATE-650



The ATE-700 is a Topcon MDD certified instrument table which is wheelchair accessible due to two separate elevation support columns. This table is suitable to accommodate one or two instruments. The ATE-700 PC version is especially designed to accommodate instruments which needs PC support. The extended table top of the ATE-700 PC version supports storage for a high end tower PC. The table top is available in white with a wooden edge finishing. The elevation stroke is 300 mm, and controlled by an easy accessible control panel, which can be programmed to memorize three predefined table heights. For safety reason the ATE-700 (PC) is equipped with a safety stopper. The ATE-700 (PC) is most suitable to accommodate Topcon's Slit Lamp range.

The Topcon ATE-600 instrument table has a central column and is available with three different table tops:

- a table top for one instrument
- a table top for two instruments
- a V-shape table top for two instruments

The ATE-650 has a fixed table top with the column on the side. This fixed table top is available in white.

- Maximum workload 80 kg
- Motorized elevation

- The ATE-700 (PC) is most suitable to accommodate Topcon's Slit Lamp range.
- Large stroke of 300 mm
- White table top with wooden edge finishing
- MDD certified
- Wheelchair accessible
- Digital control panel
- Three table top height memories
- Safety stopper
- Small footprint
- ATE-700 PC for PC storage
- Optional castors available



ATE-600



ATE-700

ATE-700 (PC)

# ATE-300



- Large stroke of 300 mm
- Table top available in two colors: white & grey
- MDD certified
- Wheelchair accessible
- Stable floor support
- Small footprint

The ATE-300 is a Topcon designed MDD certified ophthalmic instrument table with a central support column and a stable floor support which is wheelchair accessible.

The ATE-300 table top is especially designed and prepared for Topcon Slit Lamps, for easy installation of the chinrest and power supply. The table top finishing consists of a durable laminated scratch resistant top layer with a dark grey rubber profile to protect the edges.

The ATE-300 is available in a silver/white combination, the elevator stroke is 300 mm and controlled by an easy accessible control panel. The ATE-300 has high quality castors with locking mechanism that enables easy rolling of the table.





- Modern design
- Table top for one & two instruments available
- Space saving
- Simply & easy operation of the table top
- Easy wheelchair accessibility
- Large stroke of table top
- Standing & sitting position usability
- Workstation with monitor & keyboard support

The IC-1 is an innovative concept and an efficient solution for presenting instruments in your consulting room. This IC-1 instrument column is wall mounted, resulting in a very small footprint, saving you valuable floorspace and making it easy access for cleaning the floor. The IC-1 is available in two colors and can be set-up for one or even two instruments. The adjustable elevation of the table top allows for seated or standing operation of your instruments.

With the additional option of a monitor and keyboard support, this IC-1 instrument column will turn into a complete flexible workstation, which is also easily accessible for wheelchair patients. The IC-1 in combination with Topcon's Auto-Refractometer KR-1 or KR-800, along with Topcon's Tono-Pachymeter CT-1P, is the perfect solution to provide complete refractive eye care on a single square meter.



The IC-1E instrument column is part of the successful IC-1 series. In comparison to the IC-1, the IC-1E enables you to use the complete table top as a work area. The IC-1E is available with a table top for one instrument or a large table top which accommodates two instruments. The table top comes in two colors: white & blue.

The IC-1E is unique in its compact dimension and small footprint. Similar to the IC-1, the IC-1E instrument column has a remarkable large stroke of 600 mm. IC-1E is especially designed with Topcon's joystick free touchscreen instruments in mind.

- Innovative unique design
- Extremely space saving
- Easy wheelchair accessibility
- Large table top elevation stroke of 600 mm
- Standing & sitting position usability
- Table top available for one or two instruments



# Instrument Stands and Chairs

- Two instrument electrical driven parallel sliding table top
- Touchscreen control panel
- Automated linear phoropter arm VT-1L
- Powered elevation of table top
- Synchronized movement of phoropter arm with table top
- Integrated cable management system
- Wheelchair accessibility (right version)
- Various options such as monitor support & curtain control
- Large IS-1P PC-desk
- OC-14 fully reclinable ophthalmic chair available

The IS-1P is a parallel unit which is mainly designed for ophthalmic clinics and is supplied with a powered linear sliding table top to accommodate two instruments. The VT-1L linear automated phoropter arm can be synchronized with the movement of the table top, horizontally and vertically. The optional monitor support allows installation of a TFT monitor for user convenience such as Slit Lamp imaging. The optional desk will seamlessly fit to the table top which creates a larger work space and accommodation of your PC. Like IS-1 and IS-1D, this unit can be upgraded with several accessories.

The IS-1P has an option for fully automated chair movement and various functionalities can be synchronized such as curtain control, room light control and instrument auto power on/off switching. The IS-1P is controlled by a touchscreen control panel, and is available in a right version as well as a left version and a wheelchair accessible version, in various fashionable color combinations.



- Unit for three instruments
- Available in fashionable colors
- Unique touchscreen control panel
- Integrated electro brake & curtain control

The IS-1D is a unit with a rotatable table top for three instruments, which comes as standard with two electro-brakes controlled by a footswitch. Similar to IS-1 the table top can be elevated.

The IS-1D is available in right and left version as well as a wheelchair accessible version. You can choose a single trial lens drawer or a three drawers version which can optionally accommodate the power supply of the Topcon CV-5000PRO system.

The IS-1D is controlled by a touchscreen control panel for all functionalities as well as the movement of the chair. The standard curtain control, room up-light, and instrument auto on/off switching make the IS-1D a versatile ophthalmic unit for your eye care practice. The dedicated PC-desk will complete the set-up for all your needs.



- Unit for two instruments
- Available in fashionable colors
- Unique touchscreen control panel
- Both left or right configuration

The IS-1 series developed by Topcon is an ergonomic working station with full integration of Topcon instruments. A smart cabling system and predefined electronic control are part of this integration.

The Topcon IS-1 series is a versatile range of furniture for eye clinics and optician stores. There is a nearly unlimited combination of colors and configurations. A wide range of accessories will suit all needs for a modern workstation. All units from this range are available in wheelchair versions.

The IS-1 is a workstation for optician stores or eye clinics. The basic unit supports two instruments on a rotatable sliding table top which can be elevated as well. The IS-1 is operated by a touchscreen panel. The unit is available in right or left set-up and can be upgraded with optional modules such as drawers, desks, and several phoropter arms. The IS-1 can be equipped with a fully reclinable chair or a chair with a fixed back, in several colors.



The Topcon IS-600 III has been developed as a refraction unit without compromise. The IS-600 III is a comfortable and stable workstation to accommodate two instruments and can be adapted to fit various kinds of examination rooms.

For both the IS-600 III basic and IS-600 III wheelchair version there is a right and left option available. All IS-600 III configurations are equipped with a powered elevating tabletop for easy adjustments of the instrument heights for both patient and practitioner. Another option is a set of two drawers which can incorporate a power supply for the Topcon CV-5000 phoropter.

The IS-600 III can be fitted with several optional accessories such as; four different phoropter arms, chair footrest, extra drawers, tabletop electro brake and an LED reading light.

- Small footprint
- Powered elevation of tabletop
- Adjustable positioning of tabletop with electro-brake (optional)
- Various options such as LED reading light
- Dimming of room light
- Integrated cable management system
- Wheelchair accessibility

light. The intuitive touch screen control panel allows the user to control the height of the tabletop, the elevation of the chair and all lights and power to the different instruments.

### Elevated column configuration

The IS-600 III is also available with the column fixed to the instrument tabletop. When moving the tabletop up or down, the column with the phoropter will move accordingly keeping the phoropter at the same eye-level as the tabletop instruments.

- All instruments same eye-level
- No phoropter adjustment time
- No phoropter interference with other instruments



### Ophthalmic Chairs



- Small footprint
- Capacitive control panel
- Large chair elevation stroke with smooth and silent movement
- Scratch resistant and easy to clean tabletop

Topcon IS-100 has a modern design and allows two instruments on a swivel type tabletop. Its simplicity and basic functionality for an affordable price level makes the IS-100 Instrument Stand the perfect solution for the optician and optometry market. The innovative IS-100 is available in a right and left setup.

The tabletop surface is scratch resistant, fingerprint proof and easy to clean. The elevation movement of the chair provides a long stroke for easy access and is very smooth and silent.

The IS-100 accommodates all types of Slit Lamps and it provides clean cable management. Two ergonomic types of chairs are available to use with this Instrument Stand: one basic version with arm and footrests (OC-8) and a full reclinable version with footrest (OC-9).

The ophthalmic chair OC-8 and OC-9 is available with a large chair elevation stroke to provide easier access.





- Small footprint
- Economical alternative refraction lane
- Column guided cable management
- Variety of accessories
- Up-light room illumination
- Right & left hand use
- Wheelchair accessible

The FS-1 floor stand consists of a versatile column and a stable baseplate, providing an economical solution suitable for the examination room as an alternative refraction lane.

This floor stand has a small footprint and accepts several models of phoropter holders such as a balanced phoropter arm or a parallel phoropter arm as well as a chart projector bracket and a convenient reading light.

The up-light fits seamlessly in the FS-1 design providing a homogeneous room light. The FS-1 can be combined with Topcon's OC-6 ophthalmic chair or one of the IS-1 series ophthalmic chairs, such as the OC-10 or OC-12.

The small baseplate with integrated wheels permits an easy displacement of the ophthalmic chair for easy wheelchair accessibility. The optional dark grey cabinet accommodates Topcon's CV-5000 controller KB-50S as well as the CV-5000 power supply for easy printout access.



INTRODUCING

 **TOPCON** Healthcare University

# Eye Health Education Begins Here



**Topcon Healthcare University** is a new digital platform designed to meet the education and training needs of all those involved in eye health. From clinical lectures to product training, new content is added every month. Now you can get the most from your device with advanced training and education.



Register now to access our FREE collection of eye health education courses. You'll have access to engaging lectures from world-class eyecare professionals and in-depth product training courses.

## CLINICAL & BACKGROUND EDUCATION

- Basic OCT Interpretation
- Understanding Refractive Error
- Myopia Management - Putting Theory into Practice
- Glaucoma Case Studies

## PRODUCT TRAINING

- Maestro2 OCT Fundus Camera
- IMAGEnet®6 Image Review Software
- CV-5000s Digital Refraction
- SOLOS Automated Lensmeter

**Register for Topcon Healthcare University Today | [learning.topcon.com](https://learning.topcon.com)**



 **TOPCON**  
Healthcare University

# NEW OCTA Training Course Now Available from Topcon!

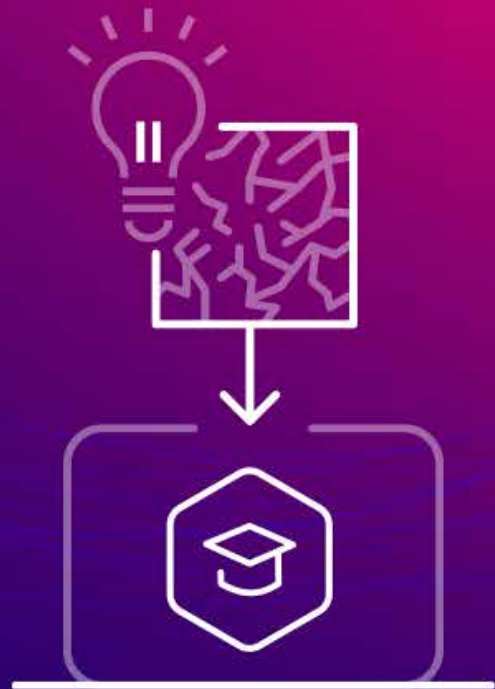

Topcon Healthcare is pleased to announce its partnership with Dr. Luis Arias, MD, PhD, in developing coursework designed to provide a deeper understanding of the clinical value of OCT Angiography (OCTA). This interactive, learning course is aimed at those new to OCTA or those considering adding OCTA to their diagnostic armory. Various patient cases are presented along with review of multimodal images captured using the Topcon DRI OCT Triton.

In addition to an “Introduction to OCTA”, other topics include comparison of OCTA to Fluorescein Angiography and Indocyanine Green Angiography, OCTA image interpretation and OCTA used for wet AMD diagnoses.

This course is available in English, German, Spanish, French.

\*This content is exclusive to Topcon Healthcare University members. Registration is free and includes access to our entire library of eye health education, including this featured course. Please note enrollment may take up to 30 minutes to complete. You can register anytime.

[learning.topcon.com](https://learning.topcon.com)



Luis Arias is the Head of the Retina Department of Ophthalmology at Bellvitge University Hospital in Barcelona, Spain, and is an Aggregate Professor of Ophthalmology at the University of Barcelona. His main areas of interest are age-related macular degeneration, pathologic myopia, diabetic retinopathy, retinal vein occlusion, macular surgery and retinal detachment. He has published extensively in peer-reviewed journals, and he has been the author of many chapters of books. Dr. Arias has received from the American Academy of Ophthalmology the International Ophthalmologist Education Award (2013) and the International Scholar Award (2016).



**TOPCON**  
Healthcare University

**IMPORTANT**

Subject to change in design and/or specifications without advanced notice.

In order to obtain the best results with this instrument, please be sure to review all user instructions prior to operation.

*Not all products, services or offers are approved or offered in every market, and products vary from one country to another.  
Contact your local distributor for country-specific information and availability.*

**TOPCON CORPORATION**

75-1, Hasunuma-cho, Itabashi-ku,  
Tokyo 174-8580, JAPAN  
Phone: +81-(0)3-3558-2522/2502  
Fax: +81-(0)3-3965-6898  
www.topconhealthcare.jp

**AUSTRALIA PTY LTD**

14 Park Way, Mawson Lakes,  
South Australia, 5095, AUSTRALIA  
Phone: +61-8-8203-3306  
E-mail: au.info@topcon.com  
www.topconhealth.com.au

**TOPCON HEALTHCARE SOLUTIONS EMEA OY**

HQ & PRODUCT DEVELOPMENT  
Saaristonkatu 9, 90100 Oulu, FINLAND  
Phone: +358-20-734-8190  
E-mail: thsemea.sales@topcon.com  
www.topconhealthcare.eu

**TOPCON EUROPE MEDICAL B.V.**

Essebaan 11, 2908 LJ Capelle a/d IJssel  
P.O. Box 145, 2900 AC Capelle a/d IJssel  
THE NETHERLANDS  
Phone: +31-(0)10-4585077  
Fax: +31-(0)10-4585045  
E-mail: medical@topcon.com  
www.topconhealthcare.eu

**TOPCON DANMARK**

Praestemarksvej 25, 4000 Roskilde  
DANMARK  
Phone: +45-46-327500  
Fax: +45-46-327555  
E-mail: info.todk@topcon.com  
www.topconhealthcare.eu

**TOPCON SCANDINAVIA**

Neongatan 2, P.O.Box 25, 43151 Mölndal  
SWEDEN  
Phone: +46-(0)31-7109200  
Fax: +46-(0)31-7109249  
E-mail: info.hcs.se@topcon.com  
www.topconhealthcare.eu

**TOPCON ESPAÑA**

Oficina Principal en España  
Frederic Mompou, 4,  
08960 Sant Just Desvern, Barcelona,  
SPAIN  
Phone: +34-93-4734057  
Fax: +34-93-4733932  
E-mail: medica@topcon.com  
www.topconhealthcare.eu/es\_ES

**TOPCON ITALY**

Viale dell' Industria 60,  
20037 Paderno Dugnano, (MI) ITALY  
Phone: +39-02-9186671  
Fax: +39-02-91081091  
E-mail: info@topcon.com  
www.topconhealthcare.eu

**TOPCON FRANCE MEDICAL**

1 rue des Vergers, Parc Swen,  
D-47877 Willich, GERMANY  
Phone: +33-(0)4-37 58 19 40,  
Fax: +33-(0)4-72 23 86 60  
E-mail: topconfrance@topcon.com  
www.topconhealthcare.eu

**TOPCON DEUTSCHLAND MEDICAL**

Hanns-Martin-Schleyer Strasse 41,  
D-47877 Willich, GERMANY  
Phone: (+49)2154-885-0  
Fax: (+49)2154-885-177  
E-mail: info@topcon-medical.de  
www.topconhealthcare.eu

**TOPCON POLSKA SP. Z. O. O.**

ul. Warszawska 23, 42-470 Siewierz  
POLAND  
Phone: +48-(0)32-670-50-45  
Fax: +48-(0)32-671-34-05  
E-mail: info.tpl@topcon.com  
www.topconhealthcare.eu

**TOPCON (GREAT BRITAIN)**

**MEDICAL LIMITED**  
Topcon House, Kennet Side, Bone Lane,  
Newbury, Berkshire RG14 5PX  
UNITED KINGDOM  
Phone: +44-(0)1635-551120  
Fax: +44-(0)1635-551170  
E-mail: medical.tgbm@topcon.com  
www.topconhealthcare.eu

**TOPCON IRELAND MEDICAL**

Unit 292, Block G, Blanchardstown,  
Corporate Park 2 Ballycoolin  
Dublin 15, D15 DX58, IRELAND  
Phone: +353-12233280  
E-mail: medical.ie@topcon.com  
www.topconhealthcare.eu